



A concentration of power in such a small space?

Industrial air motors
15M, 20M, 28M, MM, MN, MO

Reversible models - Power: from 120W up to 645W
Idle speed: from 44 up to 16.500 rpm

Non-reversible models - Power: from 150W up to 800W
Idle speed: from 50 up to 20.000 rpm

Fiam[®]
PEOPLE AND SOLUTIONS

Industrial air motors: solutions for every need

Compact, performing, light, reliable: Fiam industrial air motors represent the **ideal solution for many applications**.

Available in non-reversible or reversible version, they can advantageously be used for mixing liquid substances, moving, drilling, milling, grinding, sawing and so on. Therefore they can be **installed** on conveyor belts, machine tools, automatic feed devices and on bottling machines, foodstuff processing, packing, manufacturing of buttons and glass objects, on textiles machines, bookbinding, plastics, paint-spraying, assembly, drilling, threading, grinding, stud driving, etc.

They are **extremely sturdy** and they guarantee constant performances also in difficult working conditions.

Compact and light, they are easy to use in every situation; moreover, thanks to their **extremely reduced dimensions**, they are a quarter of the equivalent electric motor.

These motors are very versatile; they can be **customized for particular** applications requiring specific motor design and construction.

Fiam is able to develop these solutions with **customized motors** to satisfy customer's specific needs: a great competitive advantage, especially when the motor has to be integrated within a certain type of equipment or within a particular type of tool.

Reliability

Long lifetime of the components thanks to careful design and to quality of the productive process which results in less maintenance and repair costs

Innovative design principles warranty an **immediate and always guaranteed start**, also at low air feed pressure, and a **flexible functioning without vibrations**

High quality two ball bearings reductions allow to use the motors with elevated radial and/or axial loads

Weight and dimension are extremely reduced to optimize the installation also in small machines

Manufactured with materials such as high durability steel, they are **extremely resistant and sturdy**



Air motors 15M, 20M, 28M are designed and conceived for **ATEX certification** in compliance with the European standards in explosion risk environments

.....
20M

It is possible to have models manufactured with **different materials** (for example: stainless steel, plastic, special treatments) for maximum reliability in every situation



Don't be satisfied
with the maximum

Perfection for
your solutions

Naturally innovative

Productivity Ergonomics Ecology

Considerable increase of the efficiency of the tightening cycle thanks to innovative systems

The materials and the heat treatments on the reduction gears guarantee **maximum output, long lifetime and reduced noise level**

The motors are **completely modular** for faster maintenance and replacement of the spare parts in case of wear

The use of many common components **favours the supplying and the management of the spare parts**

It's possible to obtain many

customized models: with different output shafts (example: tapered, morse taper, threaded, different diameters, with gear), with different external materials and dimensions. For all models a wide range of accessories is available

These motors permit **an easy adjustment** of the torque, speed and rotation direction through simple control methods

In **reversible motors** the reverse of rotation takes place in milliseconds

The newly conceived air motor ensures **high performances also at low air feed pressure**

They are available also in **versions with low revolutions**, particularly suitable for different applications: mixing, positioning, moving, etc.

Optimization of the tool performances in regard to ergonomics and operator safety

The motors are conceived to **reduce noise level in working environment**, thanks to the use of oil separator filters for conveying the air exhaust

In compliance with European standard, Fiam motors 15M, 20M, 28M are conceived for ATEX certification (explosion risk environment); they provide the **maximum operator safety** mainly where inflammable or explosive substances are present, and in damp or high temperature environments

They haven't **any risk of overheating** also in difficult heavy duty conditions, repetitive stops/starts or inversion of rotation

Air motors MM, MN, MO are equipped with a **silencing system** that reduces the noise levels

Innovative systems designed paying even more attention with respect to environment and of its safeguard

The advanced technological design of the **air motor** permits very high decrease of **compressed air consumption**, without affecting motor performance

All the components are **easy to dispose of** because they are built using recyclable materials; therefore they do not represent any danger for environmental pollution

The use of oil separator filters for conveying the air exhaust guarantees the **absence of oil fog into the working environment**

All Fiam products are supplied with **eco-friendly packaging**

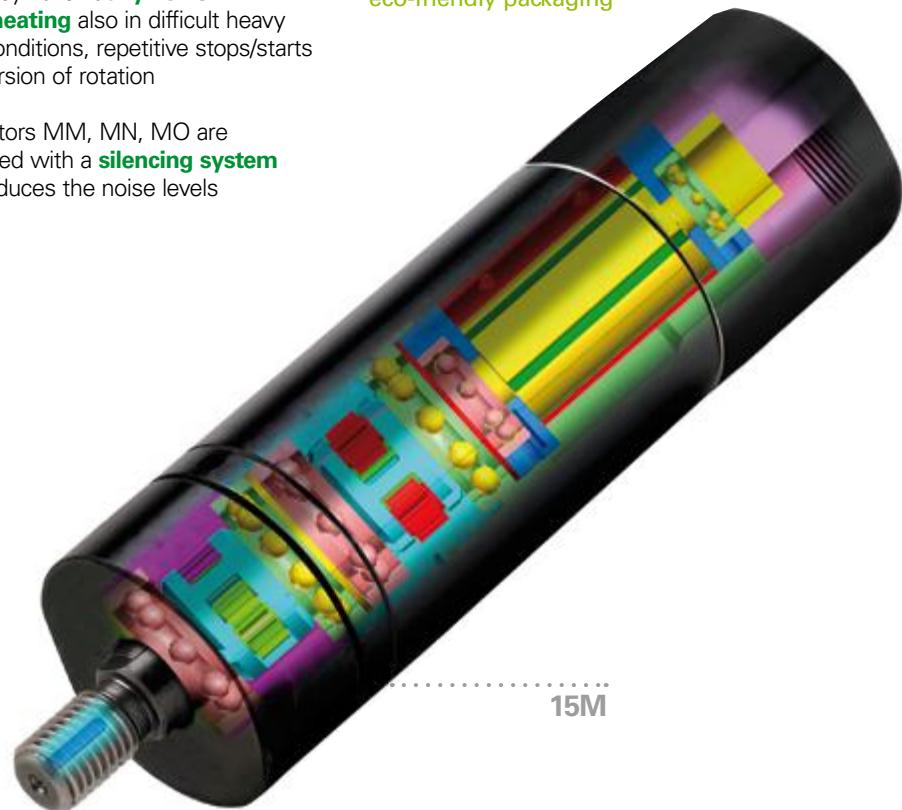
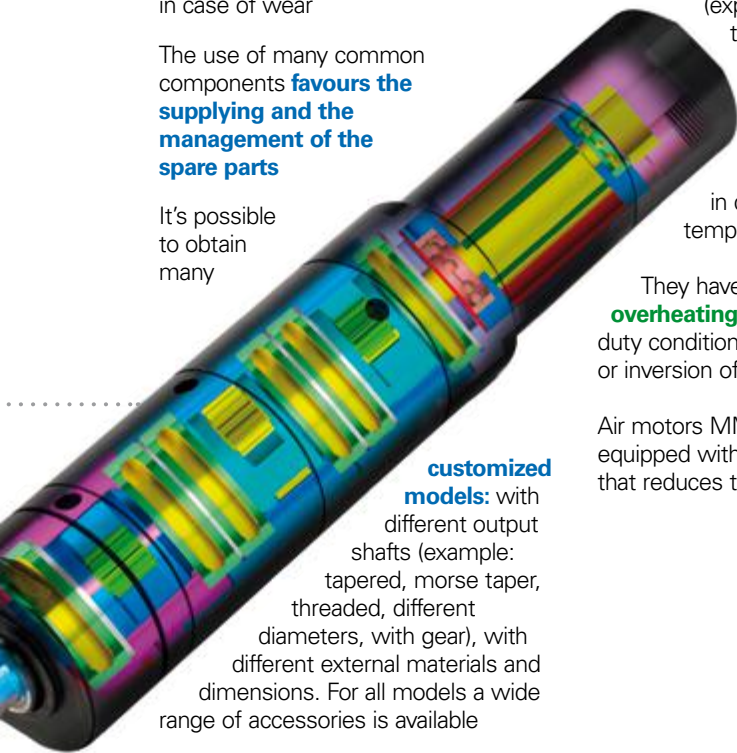

Features and performances of Fiam air motors

Performances of an air motor depend on the dynamic air inlet pressure measured at the intake of air motor; therefore by simply adjusting the air supply, using the techniques of throttling or pressure regulation, we can obtain the characteristic linear output torque/speed relationship. The performance data of the motors is valid for an air supply pressure of 6,3 bar (ISO 2787).

The main features of an air motor are:

- **Power** in Watt
- **Speed at point of maximum power**, rpm
- **Torque at maximum power**, Nm
- **Starting torque**, Nm
- **Idle speed**, rpm
- **Air consumption at maximum power**, l/s

The power

The power in Watt that an air motor produces is simply the product of torque and speed. Every motor produces a characteristic power curve, with maximum power occurring at around 50% of the idle speed. The torque produced at this point is referred to as torque at **maximum power**.

The power of an air motor is obtained with the following formula:

$$P = (\pi \times M \times n) / 30$$

Legend

P = Power in Watt

M = Torque in Nm

n = Speed (rpm)

The speed

Every air motor has an idle speed which is obtained by inserting one or more reduction gears - depending on the reduction ratio - between the driving unit and the output shaft.

At the maximum speed ("idle speed") the torque (turning moment) as taken at the output shaft, is nil, while, as load is applied, the speed will decrease inversely proportional to the torque (see chart A).

Torque at maximum power, starting torque and stall torque

The **torque at maximum power** is obtained at around 50% of idle speed that corresponds to maximum power of the motor (see chart A).

The **starting torque** is the torque that the motor gives to the output shaft under load and when you feed full air pressure into it (see chart A).

The **stall torque** is the torque that the motor gives at the output shaft when it is blocked during its rotation.

The stall torque is approximately double respect to the torque at maximum power.

How to choose an air motor

When selecting a motor, it is important to identify the '**working point**' appropriate for your application.

This '**working point**' is given by under load operating speed required by motor and by torque necessary at that speed.

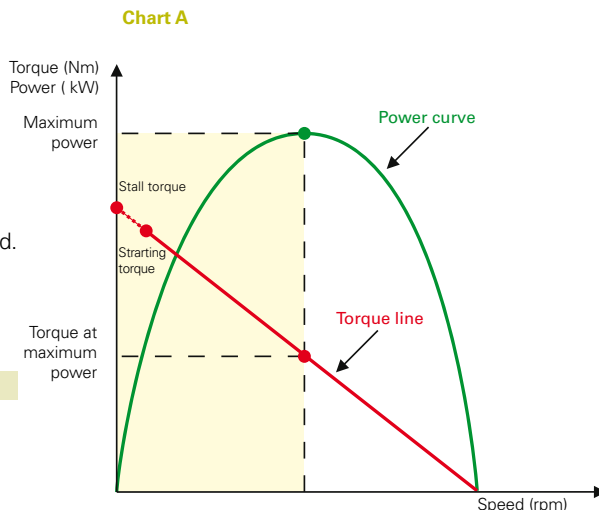

FOR EXAMPLE

A non-reversible solution to operate at 1000 r.p.m. and at 2,5 Nm is required.

It is necessary to **consider the performance curves of every model** and to identify the '**working point**' that for this example corresponds to the yellow coupon in the chart here beside.

The choice of the motor will be the one where the '**working point**' is the nearest to the torque at the maximum power (indicated by the red coupon on the chart).

The motor to be chosen is therefore model: **28M265D-D10**.

If necessary, one of the methods to reach your '**working point**' is to **act on the feed pressure** by applying the coefficients of variation of the performances parameters of the motor (see chart 1 on the page here beside).

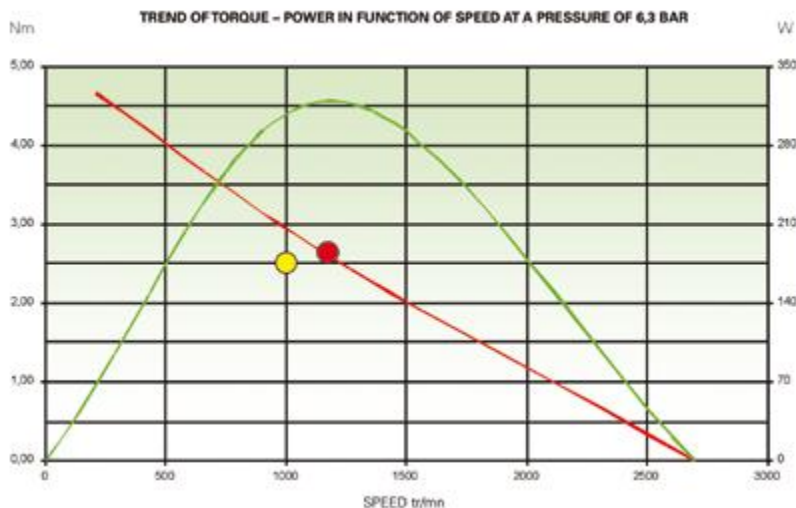

Regulation of the performances features of the motor

The performances features can be modified with continuity by means of a pressure or throttling regulator that reduces or increases the air quantity in the motor.

Consequently there is a decrease or an increase of the power, torque and speed values.

To calculate them the coefficients in chart 1 must be used.

There are **two methods to adjust** motor's performances:

- With an **air flow governor** installed before the air inlet coupling the **control of the stall torque is obtained**
- With an **air flow governor** installed on the air exhaust coupling the **stating torque is maintained and the motor's speed is adjusted;**

Chart 1

Pressure (bar)	Power	Torque	Speed	Consumption
7	1,21	1,17	1,03	1,15
6	1,00	1,00	1,00	1,00
5	0,77	0,83	0,95	0,82
4	0,55	0,67	0,87	0,65
3	0,37	0,50	0,74	0,47

Coefficients of variation of the performances parameters of an air motor in function of the feed pressure

Air feed and its consumption

The air consumption of the air motor is at **maximum** when the motor turns at **idle speed**.

To obtain the performances on catalogue it is necessary to guarantee a **correct air feeding** and air exhaust and to **follow these indications:**

- Respect always **recommended air hose bore** for air feed and exhaust hoses
- It is advisable that the **diameter of the exhaust hose** is greater than the air supply hose.
In the case of reversible motor, two inlets have to permit alternatively the entrance and the exhaust of the air i.e. that the inlet which is not used is left free so that the exhaust air can flow
- **Avoid joints and quick couplings;** they reduce the air flow
- It is always advisable to **use a FRL group** (filter, pressure regulator, lubricator) appropriate to motor consumption
- It is advisable to connect the exhaust hoses to **oil separator filter with built-in silencing system** that reduces the noise level and **lubricates the motor** without the emission of air exhaust in working environments and permits the oil to be collected and reused

Pneumatic circuit scheme (feed control of the motor)

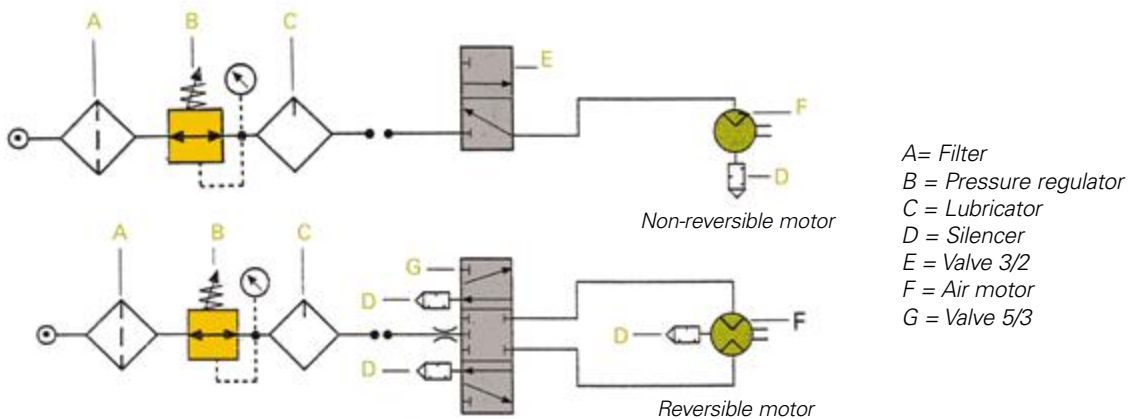

Figure 1

Models with smooth output shaft

(with key UNI 6604 form A:

Ø 6 mm for 15M; Ø 10 mm for 20M and 28M

Ø 13 mm for MM; Ø 14 mm for MN;

Ø 24 mm for MO)



Non-reversible models

Type of motor	Reversibility	Power	Speed at the max power	Torque at the max power	Static Torque	Idle speed	Air consumption at the max power	Weight				
Model	Code	Type	Watt	rpm	Nm	in lb	Nm	in lb	rpm	l/s	Kg	lb
15M1900D-D6	182711100	↻	150	9000	0,15	1.33	0,30	2.66	19000	4,4	0,32	0.70
15M550D-D6	182711500	↻	150	2500	0,60	5.31	0,95	8.41	5500	4,4	0,32	0.70
15M375D-D6	182711300	↻	150	1650	0,80	7.08	1,20	10.62	3750	4,4	0,32	0.70
15M260D-D6	182711200	↻	150	1250	1,10	9.74	1,60	14.16	2600	4,4	0,32	0.70
15M140D-D6	182712100	↻	150	600	2,20	19.47	2,90	25.67	1400	4,4	0,43	0.95
15M95D-D6	182712900	↻	150	500	2,60	23.01	4,00	35.40	950	4,4	0,43	0.95
15M70D-D6	182712700	↻	150	350	4,20*	37.17*	6,50*	57.53*	700	4,4	0,43	0.95
20M2000D-D10	183311200	↻	200	11000	0,20	1.77	0,30	2.66	20000	5,3	0,40	0.88
20M430D-D10	183311400	↻	200	2030	0,80	7.08	1,35	11.95	4300	5,3	0,40	0.88
20M260D-D10	183311210	↻	200	1350	1,25	11.06	2,10	18.59	2600	5,3	0,40	0.88
20M105D-D10	183312100	↻	200	530	3,10	27.44	5,40	47.79	1050	5,3	0,54	1.19
20M60D-D10	183312600	↻	200	305	5,30*	46.91*	8,80*	77.88*	600	5,3	0,54	1.19
28M1700D-D10	185611100	↻	280	8390	0,31	2.74	0,46	4.06	17000	6,3	0,58	1.28
28M600D-D10	185611600	↻	280	2900	1	8.83	1,5	13.25	6000	6,3	0,58	1.28
28M480D-D10	185611400	↻	280	2040	1,31	11.57	2	17.66	4800	6,3	0,58	1.28
28M330D-D10	185611300	↻	280	1510	2	17.66	2,9	25.61	3300	6,3	0,58	1.28
28M265D-D10	185611200	↻	280	1180	2,5	22.08	3,6	31.79	2650	6,3	0,58	1.28
28M155D-D10	185612100	↻	280	750	4,15	36.64	6	52.98	1550	6,3	0,78	1.72
28M120D-D10	185612110	↻	280	535	4,8	42.38	7,9	69.76	1200	6,3	0,78	1.72
28M100D-D10	185612120	↻	280	425	6,3	55.63	9	79.47	1000	6,3	0,78	1.72
28M55D-D10	185612500	↻	280	255	11,70*	103.54*	17,50*	154.87*	560	6,3	0,78	1.72
MM45	185012401	↻	260	220	11,1	98.24	22,2	196.47	440	7	1,2	2.64
MM32	185012301	↻	260	150	16,3	144.26	32,6	288.51	300	7	1,2	2.64
MM25	185012201	↻	260	110	22,2	196.47	44,4	392.94	220	7	1,2	2.64
MM13	185013101	↻	260	65	37,4	330.99	45 ③	398.25	130	7	1,48	3.26
MM9	185013901	↻	260	35	45 ③	398.25	45 ③	398.25	70	7	1,48	3.26
MM5	185013501	↻	260	25	45 ③	398.25	45 ③	398.25	50	7	1,48	3.26
MN1600	186010112	↻	375	8000	0,5	4.43	0,9	7.97	16000	10	1,45	3.19
MN480	186011412	↻	375	2400	1,6	14.16	3,1	27.44	4800	10	1,45	3.19
MN270	186011212	↻	375	1350	2,8	24.78	5,7	50.45	2700	10	1,45	3.19
MN190	186011112	↻	375	950	3,8	33.63	7,5	66.38	1900	10	1,45	3.19
MN140	186012112	↻	375	700	5	44.25	10	88.5	1400	10	1,85	4.07
MN85	186012812	↻	375	425	8,8	77.88	17,5	154.88	850	10	1,85	4.07
MN45	186012412	↻	375	225	17,3	153.11	34,5	305.33	450	10	1,85	4.07
MN32	186012313	↻	375	160	22	194.7	44,5	393.83	320	10	1,85	4.07
MN22	186012212	↻	375	110	29	256.65	45 ③	398.25	220	10	1,85	4.07
MO1550	187010102	↻	800	7750	1,6	14.16	3	26.55	15500	18	3,3	7.26
MO450	187011402	↻	800	2250	5,2	46.02	10	88.5	4500	18	3,4	7.48
MO280	187011202	↻	800	1400	9,3	82.31	18	159.3	2800	18	3,4	7.48
MO130	187012102	↻	800	650	16	141.6	31	274.35	1300	18	4,1	9.02
MO85	187012802	↻	800	425	26,5	234.53	52	460.2	850	18	4,1	9.02
MO40	187013402	↻	800	200	50	442.5	90 ③	796.5	400	18	4,8	10.56
MO25	187013202	↻	800	125	80	708	90 ③	796.5	250	18	4,8	10.56

* The maximum torque permitted, for continuous use, is 4 Nm for 15M70D-D6, from 4 to 5 Nm for 20M60D-D10 and 8 Nm for 28M55D-D10

③ The torque indicated is the maximum at which the motor can be used in order to guarantee the life endurance of the internal gears



Reversible models

Type of motor	Reversibility	Power	Speed at the max power	Torque at the max power	Static Torque	Idle speed	Air consumption at the max power	Weight				
Model	Code	Type	Watt	rpm	Nm	in lb	Nm	in lb	rpm	l/s	Kg	lb
15M1600R-D6	182911100	☺☺☺	120	8300	0,15	1.33	0,20	1.77	16000	4,3	0,32	0.70
15M440R-D6	182911400	☺☺☺	120	2200	0,60	5.31	0,80	7.08	4400	4,3	0,32	0.70
15M300R-D6	182911300	☺☺☺	120	1490	0,75	6.64	1,00	8.85	3000	4,3	0,32	0.70
15M220R-D6	182911200	☺☺☺	120	1100	1,05	9.29	1,50	13.28	2200	4,3	0,32	0.70
15M120R-D6	182912100	☺☺☺	120	590	1,90	16.82	2,60	23.01	1200	4,3	0,43	0.95
15M80R-D6	182912800	☺☺☺	120	410	2,50	22.13	3,60	31.86	800	4,3	0,43	0.95
15M58R-D6	182912500	☺☺☺	120	300	4,00*	35.40*	5,50*	48.68*	580	4,3	0,43	0.95
20M1650R-D10	183511100	☺☺☺	160	9000	0,15	1.33	0,25	2.21	16500	5,0	0,40	0.88
20M400R-D10	183511300	☺☺☺	160	1950	0,80	7.08	1,20	10.62	4000	5,0	0,40	0.88
20M250R-D10	183511200	☺☺☺	160	1330	1,40	12.39	2,20	19.47	2500	5,0	0,40	0.88
20M100R-D10	183512900	☺☺☺	160	550	3,05	26.99	4,80	42.48	1000	5,0	0,54	1.19
20M58R-D10	183512500	☺☺☺	160	300	5,70*	50.45*	7,50*	66.38*	580	5,0	0,54	1.19
28M1300R-D10	185811100	☺☺☺	210	6200	0,27	2.38	0,45	3.97	13000	5,8	0,58	1.28
28M415R-D10	185811400	☺☺☺	210	2075	0,85	7.51	1,2	10.60	4150	5,8	0,58	1.28
28M345R-D10	185811300	☺☺☺	210	1675	1,25	11.04	1,65	14.57	3450	5,8	0,58	1.28
28M235R-D10	185811200	☺☺☺	210	1230	1,8	15.89	2,4	21.19	2350	5,8	0,58	1.28
28M190R-D10	185811110	☺☺☺	210	855	2,3	20.31	2,9	25.61	1850	5,8	0,58	1.28
28M110R-D10	185812100	☺☺☺	210	500	3,9	34.44	5,1	45.03	1100	5,8	0,78	1.72
28M90R-D10	185812900	☺☺☺	210	410	4,7	41.50	6,8	60.04	900	5,8	0,78	1.72
28M70R-D10	185812700	☺☺☺	210	330	6,2	54.87	8	70.64	700	5,8	0,78	1.72
28M40R-D10	185812400	☺☺☺	210	190	11,50*	101.77*	15,50*	137.17*	395	5,8	0,78	1.72
MM45R/2 E	185212401	☺☺☺	240	210	10,5	92.93	21	185.85	420	7	1,22	2.68
MM32R/2 E	185212301	☺☺☺	240	145	15,2	134.52	30,4	269.04	290	7	1,22	2.68
MM25R/2 E	185212201	☺☺☺	240	105	20,9	184.97	41,8	369.93	210	7	1,22	2.68
MM13R/2 E	185213101	☺☺☺	240	60	36,3	321.26	45 ☺	398.25	120	7	1,50	3.3
MM9R/2 E	185213901	☺☺☺	240	32	45 ☺	398.25	45 ☺	398.25	64	7	1,50	3.3
MM5R/2 E	185213501	☺☺☺	240	22	45 ☺	398.25	45 ☺	398.25	44	7	1,50	3.3
MN1500R	186210112	☺☺☺	375	7500	0,5	4.43	0,9	7.97	15000	10	1,45	3.19
MN450R	186211412	☺☺☺	375	2250	1,6	14.16	3,1	27.44	4500	10	1,45	3.19
MN250R	186211212	☺☺☺	375	1250	2,8	24.78	5,7	50.45	2500	10	1,45	3.19
MN170R	186211112	☺☺☺	375	850	3,8	33.63	7,5	66.38	1700	10	1,45	3.19
MN130R	186212112	☺☺☺	375	650	5	44.25	10	88.5	1300	10	1,85	4.07
MN80R	186212812	☺☺☺	375	400	8,5	75.23	17	150.45	800	10	1,85	4.07
MN40R	186212412	☺☺☺	375	200	16	141.6	32	283.2	400	10	1,85	4.07
MN28R	186212313	☺☺☺	375	140	21	185.85	42	331.7	280	10	1,85	4.07
MN20R	186212212	☺☺☺	375	100	28	247.8	45 ☺	398.25	200	10	1,85	4.07
MO1200R	187210102	☺☺☺	645	6000	1,3	11.51	2,5	22.13	12000	18	3,3	7.26
MO360R	187211302	☺☺☺	645	1800	4,2	37.17	8	70.8	3600	18	3,4	7.48
MO220R	187211202	☺☺☺	645	1100	7,7	68.15	15	132.75	2200	18	3,4	7.48
MO110R	187212102	☺☺☺	645	550	14,3	126.56	28	247.8	1100	18	4,1	9.02
MO70R	187212702	☺☺☺	645	350	25	221.25	49	433.65	700	18	4,1	9.02
MO32R	187213302	☺☺☺	645	160	48	424.8	90 ☺	796.5	320	18	4,8	10.56
MO20R	187213202	☺☺☺	645	100	77	681.45	90 ☺	796.5	200	18	4,8	10.56

* The maximum torque permitted, for continuous use, is 4 Nm for 15M58R-D6, from 4 to 5 Nm for 20M58R-D10 and 8 Nm for 28M40R-D10

☺ The torque indicated is the maximum at which the motor can be used in order to guarantee the life endurance of the internal gears

Models with threaded output shaft

(5/16"×24UNF for 15M;
3/8"×24UNF for 28M and 20M)

Ideal to use the motors in drilling, burring, etc. operations.

Available only for version with clockwise rotation.



Non-reversible models

Type of motor		Reversibility	Power	Speed at the max power	Torque at the max power		Static Torque		Idle speed	Air consumption at the max power	Weight	
Model	Code	Type	Watt	rpm	Nm	in lb	Nm	in lb	rpm	l/s	Kg	lb
15M1900D-5/16x24UNF	182741100	↻	150	9000	0,15	1.33	0,30	2.66	19000	4,4	0,32	0.70
15M550D-5/16x24UNF	182741500	↻	150	2500	0,60	5.31	0,95	8.41	5500	4,4	0,32	0.70
15M375D-5/16x24UNF	182741300	↻	150	1650	0,80	7.08	1,20	10.62	3750	4,4	0,32	0.70
15M260D-5/16x24UNF	182741200	↻	150	1250	1,10	9.74	1,60	14.16	2600	4,4	0,32	0.70
15M140D-5/16x24UNF	182742100	↻	150	600	2,20	19.47	2,90	25.67	1400	4,4	0,43	0.95
15M95D-5/16x24UNF	182742900	↻	150	500	2,60	23.01	4,00	35.40	950	4,4	0,43	0.95
15M70D-5/16x24UNF	182742700	↻	150	350	4,20*	37.17*	6,50*	57.53*	700	4,4	0,43	0.95
20M2000D-3/8x24UNF	183341200	↻	200	11000	0,20	1.77	0,30	2.66	20000	5,3	0,40	0.88
20M430D-3/8x24UNF	183341400	↻	200	2030	0,80	7.08	1,35	11.95	4300	5,3	0,40	0.88
20M260D-3/8x24UNF	183341210	↻	200	1350	1,25	11.06	2,10	18.59	2600	5,3	0,40	0.88
20M105D-3/8x24UNF	183342100	↻	200	530	3,10	27.44	5,40	47.79	1050	5,3	0,54	1.19
20M60D-3/8x24UNF	183342600	↻	200	305	5,30*	46.91*	8,80*	77.88*	600	5,3	0,54	1.19
28M1700D-3/8x 24UNF	185609001	↻	280	8390	0,31	2.74	0,46	4.06	17000	6,3	0,58	1.28
28M600D-3/8x24UNF	185609002	↻	280	2900	1	8.83	1,5	13.25	6000	6,3	0,58	1.28
28M480D-3/8x24UNF	185609003	↻	280	2040	1,31	11.57	2	17.66	4800	6,3	0,58	1.28
28M330D-3/8x24UNF	185609004	↻	280	1510	2	17.66	2,9	25.61	3300	6,3	0,58	1.28
28M265D-3/8x24UNF	185609005	↻	280	1180	2,5	22.08	3,6	31.79	2650	6,3	0,58	1.28
28M155D-3/8x24UNF	185609006	↻	280	750	4,15	36.64	6	52.98	1550	6,3	0,78	1.72
28M120D-3/8x24UNF	185609007	↻	280	535	4,8	42.38	7,9	69.76	1200	6,3	0,78	1.72
28M100D-3/8x24UNF	185609008	↻	280	425	6,3	55.63	9	79.47	1000	6,3	0,78	1.72
28M55D-3/8x24UNF	185609009	↻	280	255	11,70*	103.54*	17,50*	154.87*	560	6,3	0,78	1.72

* The maximum torque permitted, for continuous use, is 4 Nm for 15M70D-5/16x24UNF, from 4 to 5 Nm for 20M60D-3/8x24UNF and 8 Nm for 28M55D-3/8x24UNF

Version available also for MM, MN, MO air motors. For further information please contact Fiam Technical Consultancy Service

Models with collet shaft

(collet chuck included:
ER11 for 20M; ER16 for 28M)

They are indispensable when the use of collets reduces the dimensions of encumbrance of the head of the drilling unit thus ensuring more accuracy in drilling.

Available only for version with clockwise rotation.

The collet is excluded, see Accessories available upon request.



Non-reversible models

Type of motor	Code	Reversibility	Power	Speed at the max power	Torque at the max power		Static Torque		Idle speed	Air consumption at the max power	Weight	
Model	Code	Type	Watt	rpm	Nm	in lb	Nm	in lb	rpm	l/s	Kg	lb
20M2000D-ER11	183331200	↻	200	11000	0,20	1,77	0,30	2,66	20000	5,3	0,40	0,88
20M430D-ER11	183331400	↻	200	2030	0,80	7,08	1,35	11,95	4300	5,3	0,40	0,88
20M260D-ER11	183331210	↻	200	1350	1,25	11,06	2,10	18,59	2600	5,3	0,40	0,88
20M105D-ER11	183332100	↻	200	530	3,10	27,44	5,40	47,79	1050	5,3	0,54	1,19
20M60D-ER11	183332600	↻	200	305	5,30*	46,91*	8,80*	77,88*	600	5,3	0,54	1,19
28M1700D-ER16	185609012	↻	280	8390	0,31	2,74	0,46	4,06	17000	6,3	0,67	1,47
28M600D-ER16	185609013	↻	280	2900	1	8,83	1,5	13,25	6000	6,3	0,67	1,47
28M480D-ER16	185609014	↻	280	2040	1,31	11,57	2	17,66	4800	6,3	0,67	1,47
28M330D-ER16	185609015	↻	280	1510	2	17,66	2,9	25,61	3300	6,3	0,67	1,47
28M265D-ER16	185609016	↻	280	1180	2,5	22,08	3,6	31,79	2650	6,3	0,67	1,47
28M155D-ER16	185609017	↻	280	750	4,15	36,64	6	52,98	1550	6,3	0,87	1,91
28M120D-ER16	185609018	↻	280	535	4,8	42,38	7,9	69,76	1200	6,3	0,87	1,91
28M100D-ER16	185609019	↻	280	425	6,3	55,63	9	79,47	1000	6,3	0,87	1,91
28M55D-ER16	185609020	↻	280	255	11,70*	103,54*	17,50*	154,87*	560	6,3	0,87	1,91

* The maximum torque permitted, for continuous use, is from 4 to 5 Nm for 20M60D-ER11 and 8 Nm for 28M55D-ER16

Version available also for MM, MN, MO air motors. For further information please contact Fiam Technical Consultancy Service

Legend

15/20/28M... = Power of the motor in Watt/10 • M = Air motor • 1700 = Revolutions/10 • D = Right (non-reversible) • D10 = Smooth output shaft ø 10 mm with key UNI 6604 form A • D6 = Smooth output shaft ø 6 mm with key UNI 6604 form A • 3/8" x 24UNF = Threaded output shaft 3/8" x 24UNF • 5/16" x 24UNF = Threaded output shaft 5/16" x 24UNF • ER16 = Collet shaft ER16 • ER11 = Collet shaft ER11

Legend

↻ reversibility: right and left

↻ reversibility: right (clockwise)
the direction in which the output shaft turns in considered to be in function of the delivery air input

- The figures shown are measured at a pressure of 6,3 bar (ISO 2787), the recommended operating pressure
- Working air pressure: max 7 bar.
- The code number must be used when ordering.

The above figures should be used as a guide only and could be changed without notice. For all further details, please apply to the Fiam Technical Consultancy Service.

N.B. The noise level in the motors is generated by the air exhaust. The level increases as the speed increases and it is at the maximum when the motor rotates at idle speed. All the motors are supplied with a threaded connection which is needed to connect, with a suitable coupling, a hose conveyor in order to take the exhaust air away from the working environment. Fiam recommends to convey the exhaust air to an oil separator filter with built-in silencing system which also permits to give an adequate lubrication to the motors without polluting the working environment.

* The maximum torque permitted, for continuous use, is 8 Nm for 28M, from 4 to 5 Nm for 20M and 4 Nm for 15M.

Other technical features

Model	Air inlet	Recommended hose bore
MM	1/4" gas	Ø 6 mm
MN	1/4" gas	Ø 8 mm
MO	3/8" gas	Ø 13 mm
28M...D/R	1/8" gas	Ø 6 mm
20M...D/R	1/8" gas	Ø 6 mm
15M...D/R	1/8" gas	Ø 6 mm

Models available upon request

- Models with different output shafts: tapered, morse taper, with gear, shafts with different diameter
- Models with only anti clockwise rotation (except models with threaded shaft)
- Models with flanged sleeves
- Special models customised for client
- Models with housing and output shaft made of different materials (e.g.: stainless steel, plastic...)
- Models with ATEX certification (only for 15/20/28M)
- Models with smooth output shaft ø 13 mm (for 20M)

Models with low rotations with smooth output shaft

(\varnothing 10 mm with key UNI 6604 form A)
 maximum torque permitted:
 4-5 Nm (for 20M); 8 Nm (for 28M)

These motors are suitable for many applications: mixing, moving, components positioning, various movements, etc. and they are used in many industrial applications.

The leading technical factor for the choice is the low rotation speed; it isn't the working torque as for standard industrial motors.

The use of these motors is particular. **They must not be used according to torque range**, otherwise on stall they could reach very high torques and compromise the inner kinematic gears of the motor. Therefore the load must be regulated in such way that the torque does not exceed the 4-5 Nm for 20M, 8Nm for 28M.



Non-reversible models

Type of motor	Code	Reversibility	Power	Idle speed	Air consumption	Weight
Model	Code	Type	Watt	rpm	l/s	Kg / lb
20M35D-D10	183312300	↻	200	350	5,3	0,54 / 1,19
20M14D-D10	183313100	↻	200	140	5,3	0,70 / 1,54
20M8D-D10	183313800	↻	200	80	5,3	0,70 / 1,54
20M5D-D10	183313500	↻	200	50	5,3	0,70 / 1,54
28M20D-D10	185613200	↻	280	215	6	0,97 / 2,13
28M10D-D10	185613100	↻	280	100	6	0,97 / 2,13

Reversible models

Model	Code	Type	Watt	rpm	l/s	Kg	lb
20M30R-D10	183512300	↻↻	160	300	5,0	0,54	1,19
20M13R-D10	183513100	↻↻	160	130	5,0	0,70	1,54
20M7R-D10	183513800	↻↻	160	70	5,0	0,70	1,54
20M4R-D10	183513500	↻↻	160	40	5,0	0,70	1,54
28M15R-D10	185813100	↻↻	210	150	5,8	0,97	2,13
28M8R-D10	185813800	↻↻	210	75	5,8	0,97	2,13

Legend

28 = Power of the motor in Watt/10 • M = Air motor • 10 = Revolutions/10 • D = Right (non-reversible) • R = Reversible • D10 = Smooth output shaft \varnothing 10 mm with key UNI 6604 form A

Legend

↻ reversibility: right and left

↻↻ reversibility: right (clockwise) the direction in which the output shaft turns in considered to be in function of the delivery air input

- The figures shown are measured at a pressure of 6,3 bar (ISO 2787), the recommended operating pressure
- Working air pressure: max 7 bar.
- The code number must be used when ordering.

The above figures should be used as a guide only and could be changed without notice. For all further details, please apply to the Fiam Technical Consultancy Service.

N.B. The noise level in the motors is generated by the air exhaust. The level increases as the speed increases and it is at the maximum when the motor rotates at idle speed. All the motors are supplied with a threaded connection which is needed to connect, with a suitable coupling, a hose conveyor in order to take the exhaust air away from the working environment. Fiam recommends to convey the exhaust air to an oil separator filter with built-in silencing system which also permits to give an adequate lubrication to the motors without polluting the working environment.

Other technical features

Model	Air inlet	Recommended hose bore	Output shaft
20M...D/R 28M...D/R	1/8" gas	\varnothing 6 mm	Smooth shaft \varnothing 10 mm with key (UNI 6604 form A)

Models available upon request

- Models with rotations lower than those indicated in chart
- Models with different output shafts: threaded 3/8 x 24 UNF, tapered, morse taper, with gear, shafts with different diameter
- Models with only anti clockwise rotation
- Models with flanged sleeves
- Special models customised for client
- Models with housing and output shaft made of different materials (e.g.: stainless steel, plastic...)
- Models with ATEX certification

Dimensions

Models with smooth output shaft

(with key UNI 6604 form A: \varnothing 6 mm for 15M; \varnothing 10 mm for 20M and 28M; \varnothing 13 mm for MM; \varnothing 14 mm for MN; \varnothing 24 mm for MO)

Dimensions (mm)

Model	L	L1
15M1900D-D6	94,5	-
15M550D-D6	94,5	-
15M375D-D6	94,5	-
15M260D-D6	94,5	-
15M140D-D6	120	-
15M95D-D6	120	-
15M70D-D6	120	-
15M1600R-D6	94,5	-
15M440R-D6	94,5	-
15M300R-D6	94,5	-
15M220R-D6	94,5	-
15M120R-D6	120	-
15M80R-D6	120	-
15M58R-D6	120	-
20M2000D - D10	103	-
20M430D - D10	103	-
20M260D - D10	103	-
20M105D - D10	134	-
20M60D - D10	134	-
20M1650R - D10	103	-
20M400R - D10	103	-
20M250R - D10	103	-
20M100R - D10	134	-
20M58R - D10	134	-
28M1700D-D10	134,5	111
28M600D-D10	134,5	111
28M480D-D10	134,5	111
28M330D-D10	134,5	111
28M265D-D10	134,5	111
28M155D-D10	165,5	142
28M120D-D10	165,5	142
28M100D-D10	165,5	142
28M55D-D10	165,5	142
28M1300R-D10	134,5	111
28M415R-D10	134,5	111
28M345R-D10	134,5	111
28M235R-D10	134,5	111
28M190R-D10	134,5	111
28M110R-D10	165,5	142
28M90R-D10	165,5	142
28M70R-D10	165,5	142
28M40R-D10	165,5	142
MM45 - MM45R/2E	133,5	-
MM32 - MM32R/2E	133,5	-
MM25 - MM25R/2E	133,5	-
MM13 - MM13R/2E	167,5	-
MM9 - MM9R/2E	167,5	-
MM5 - MM5R/2E	167,5	-
MN1600 - MN1500R	149	-
MN480 - MN450R	149	-
MN270 - MN250R	149	-
MN190 - MN170R	149	-
MN140 - MN130R	183	-
MN85 - MN80R	183	-
MN45 - MN40R	183	-
MN32 - MN28R	183	-
MN22 - MN20R	183	-
MO1550 - MO1200R	177,5	-
MO450 - MO360R	187	-
MO280 - MO220R	187	-
MO130 - MO110R	222	-
MO85 - MO70R	222	-
MO40 - MO32R	257	-
MO25 - MO20R	257	-

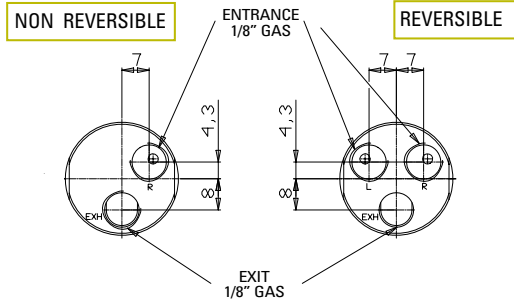
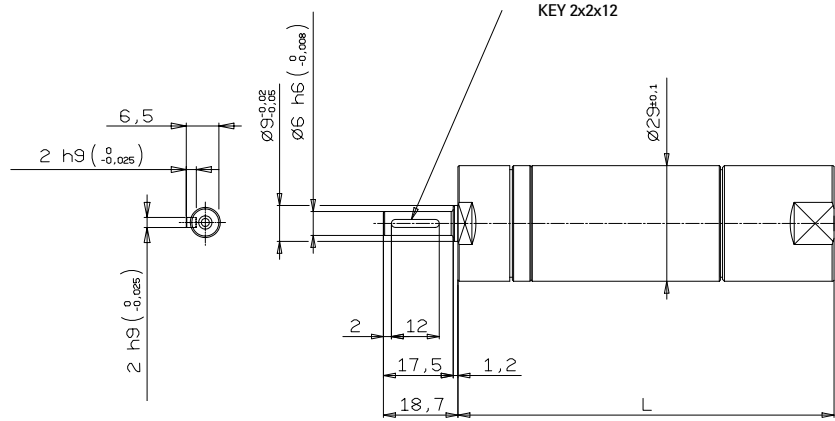

15M models

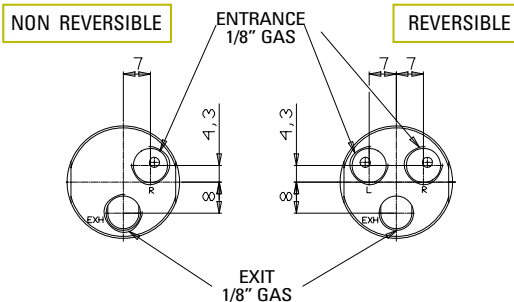
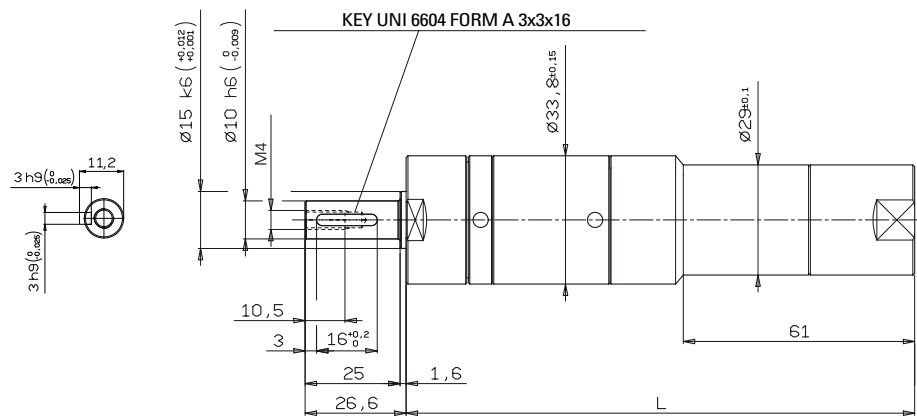

20M models

Models with smooth output shaft

(with key UNI 6604 form A: \varnothing 6 mm for 15M; \varnothing 10 mm for 20M and 28M; \varnothing 13 mm forr MM; \varnothing 14 mm for MN; \varnothing 24 mm for MO)

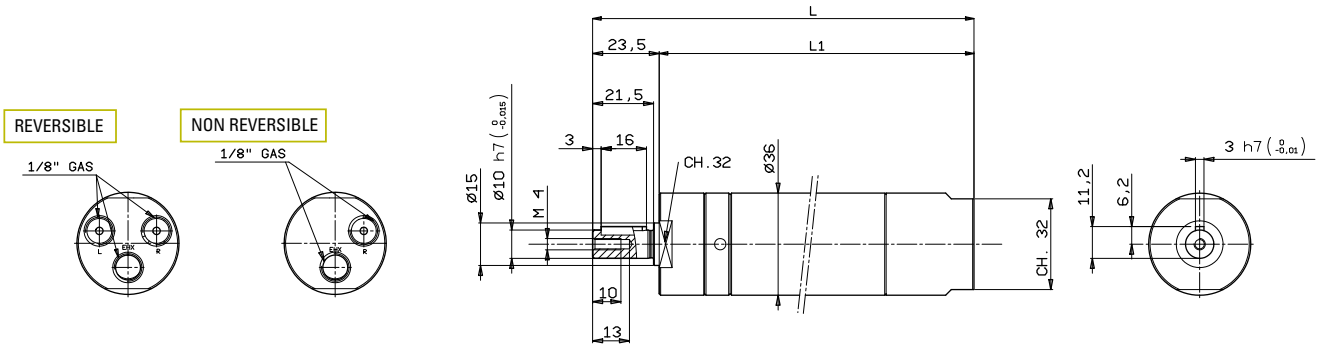

28M models

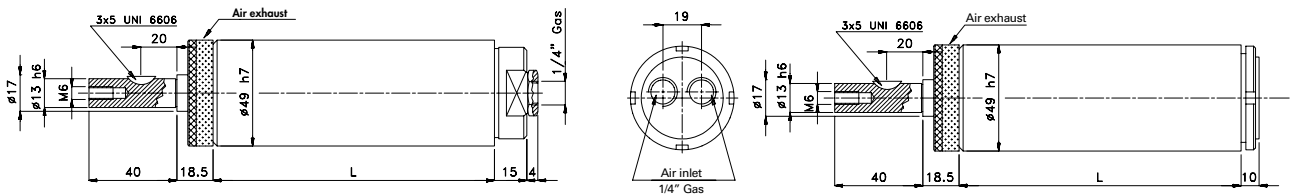

MM models

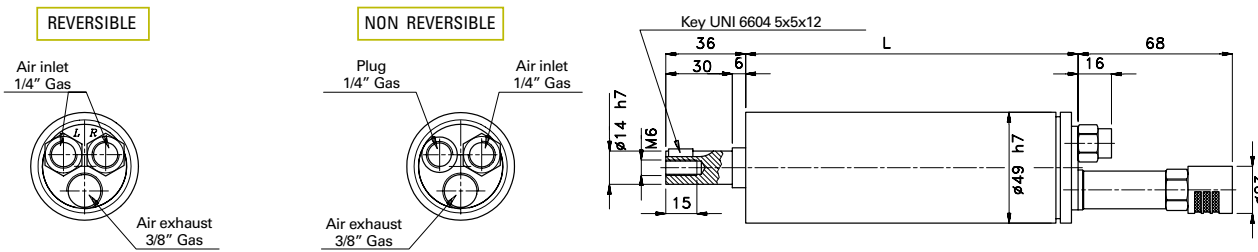

MN models

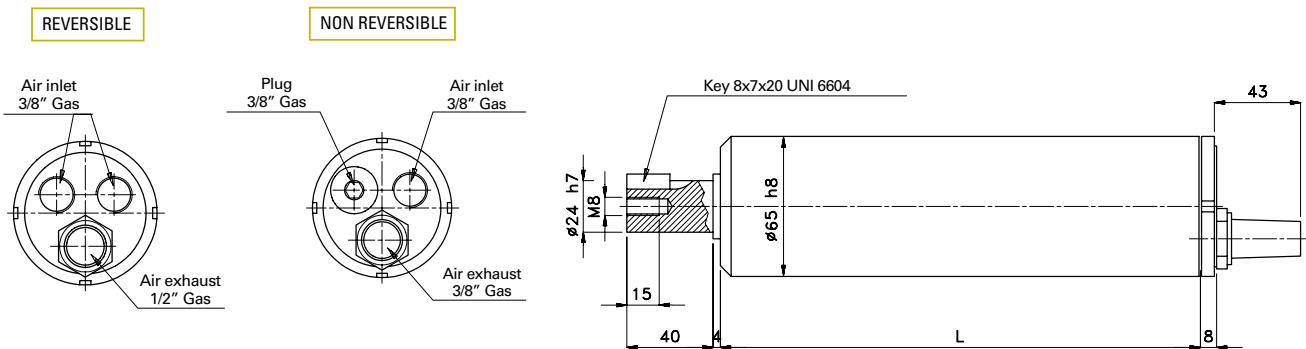

MO models

Models with threaded output shaft

(5/16"x24UNF for 15M; 3/8"x24UNF for 28M and 20M)

Dimensions (mm)

Model	L	L1
15M1900D-5/16x24UNF	94,5	-
15M550D-5/16x24UNF	94,5	-
15M375D-5/16x24UNF	94,5	-
15M260D-5/16x24UNF	94,5	-
15M140D-5/16x24UNF	120	-
15M95D-5/16x24UNF	120	-
15M75D-5/16x24UNF	120	-
20M2000D-3/8x24UNF	103	-
20M430D-3/8x24UNF	103	-
20M260D-3/8x24UNF	103	-
20M105D-3/8x24UNF	134	-
20M60D-3/8x24UNF	134	-
28M1700D - 3/8x24UNF	126,5	107
28M600D - 3/8x24UNF	126,5	107
28M480D - 3/8x24UNF	126,5	107
28M330D - 3/8x24UNF	126,5	107
28M265D - 3/8x24UNF	126,5	107
28M155D - 3/8x24UNF	157,5	138
28M120D - 3/8x24UNF	157,5	138
28M100D - 3/8x24UNF	157,5	138
28M55D - 3/8x24UNF	157,5	138

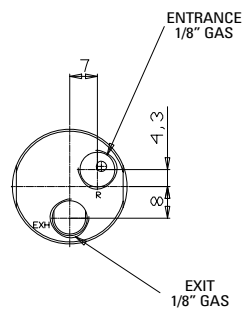
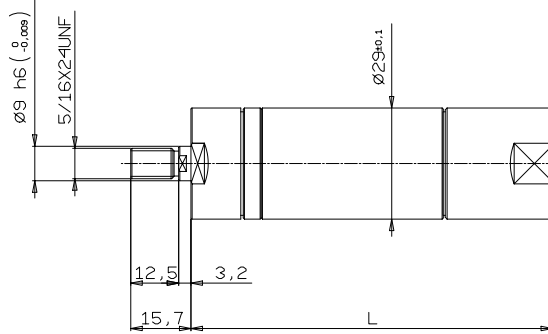

15M models

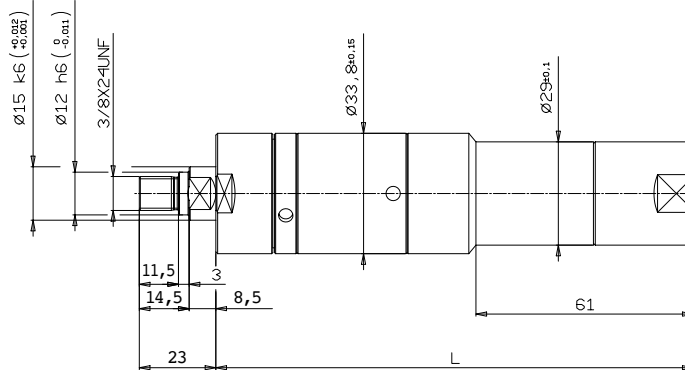
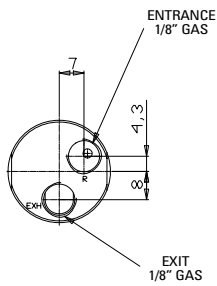

20M models

NON REVERSIBLE

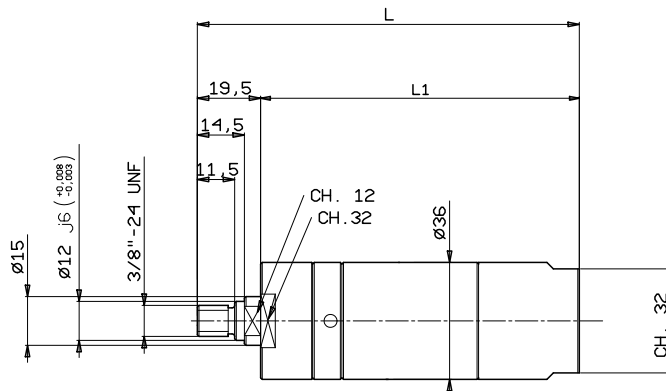
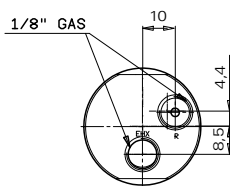

28M models

Models with collet shaft

(collet chuck included: ER11 for 20M; ER16 for 28M)

Dimensions (mm)

Model	L	L1
20M2000D-ER11	103	-
20M430D-ER11	103	-
20M260D-ER11	103	-
20M105D-ER11	134	-
20M60D-ER11	134	-
28M1700D - ER16	162	107
28M600D - ER16	162	107
28M480D - ER16	162	107
28M330D - ER16	162	107
28M265D - ER16	162	107
28M155D - ER16	193	138
28M120D - ER16	193	138
28M100D - ER16	193	138
28M55D - ER16	193	138

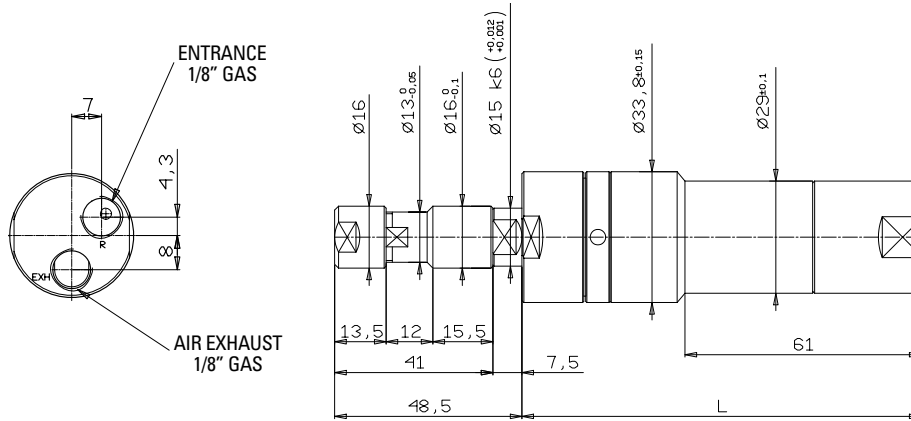

20M models

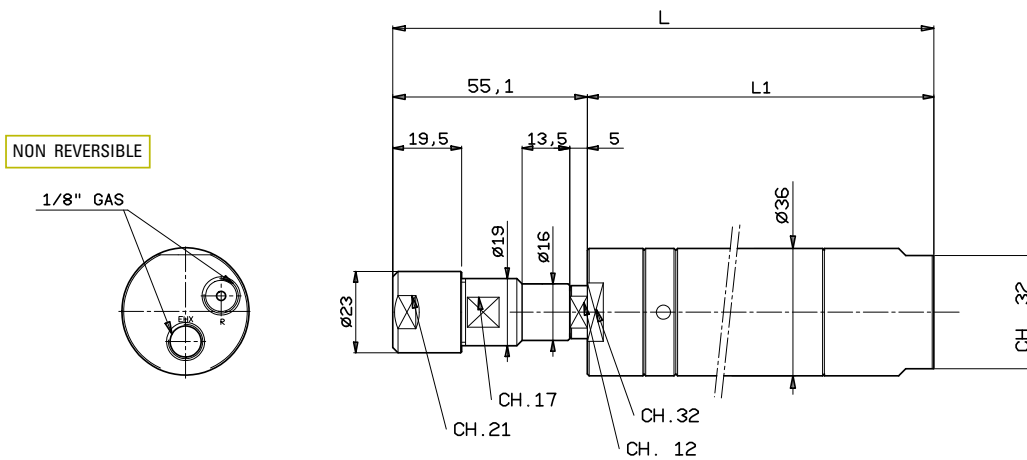

28M models

Models with low rotations with smooth output shaft

(with key UNI 6604 form A: \varnothing 6 mm for 20M; \varnothing 10 mm for 28M)

Dimensions (mm)

Model	L	L1
20M35D-D10	134	-
20M14D-D10	165	-
20M8D-D10	165	-
20M5D-D10	165	-
20M30R-D10	134	-
20M13R-D10	165	-
20M7R-D10	165	-
20M4R-D10	165	-
28M20D	196,5	173
28M10D	196,5	173
28M15R	196,5	173
28M8R	196,5	173

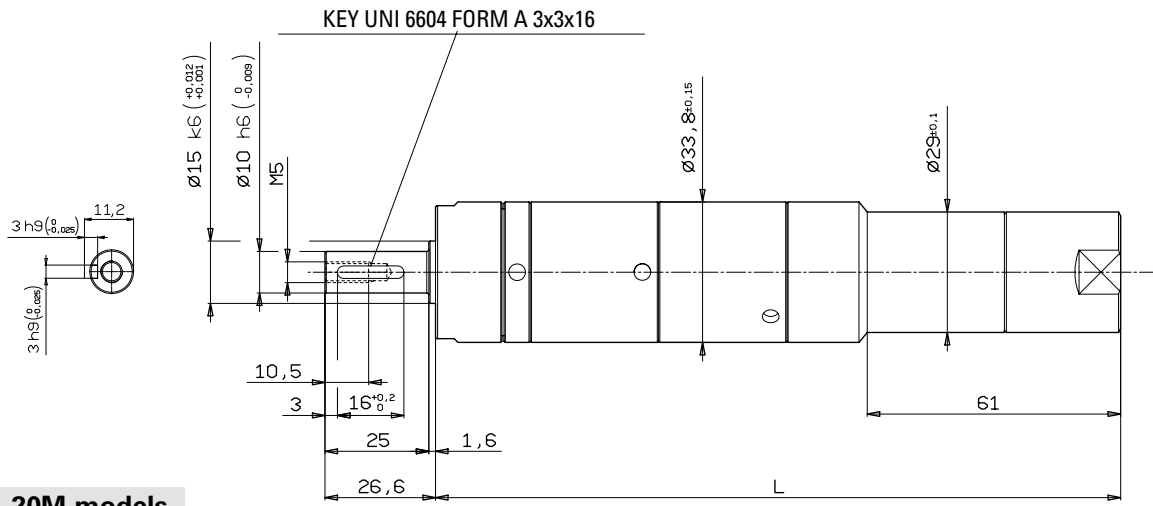
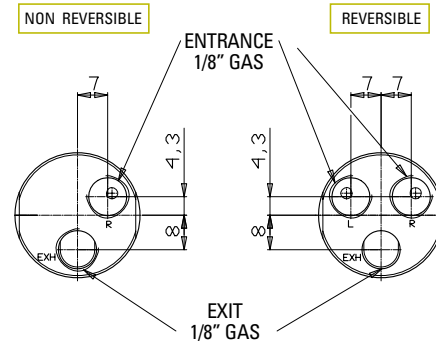

20M models

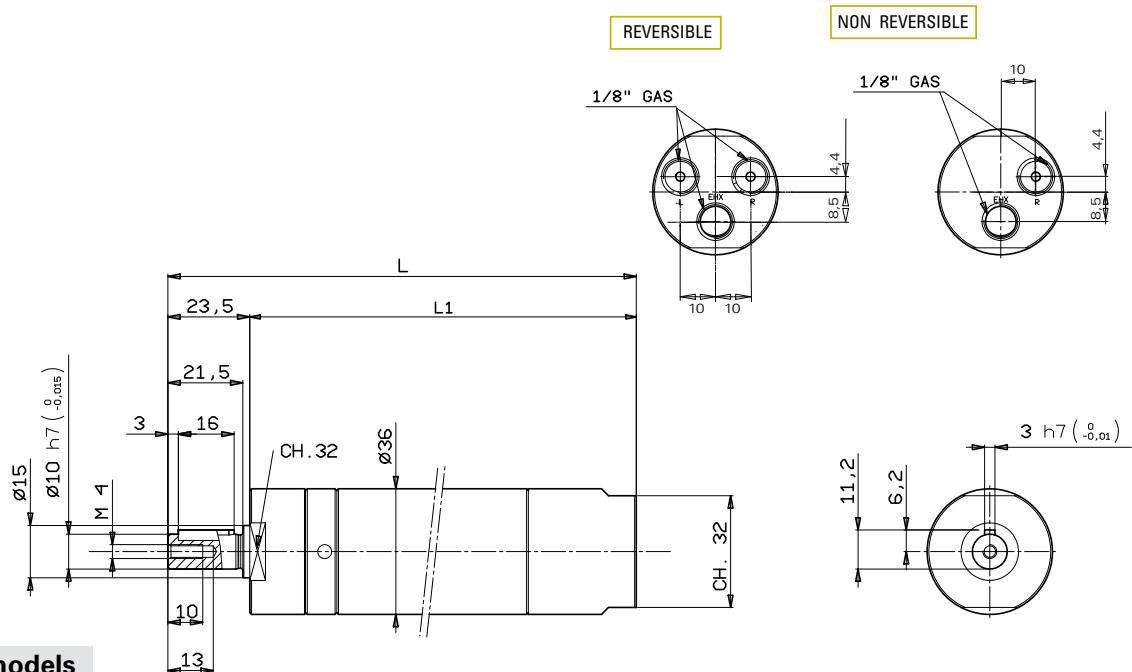

28M models

Performances diagrams of torque, power and speed

The diagrams show the curves for torque and power in function of number of revolutions: torque — power —
Trend of torque - power in function of speed (at a pressure of 6,3 bar)

Non-reversible models

Models 15M...

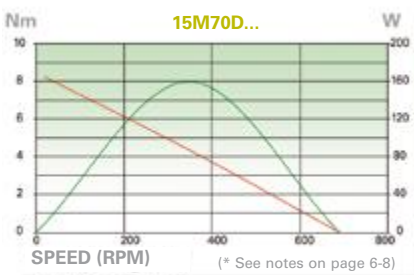
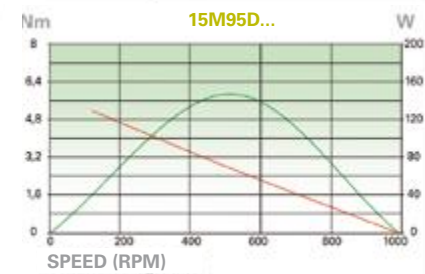
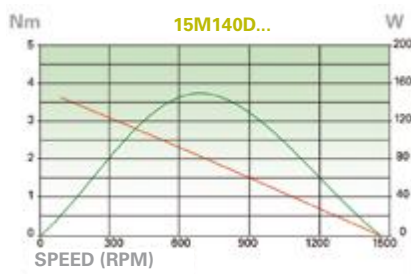
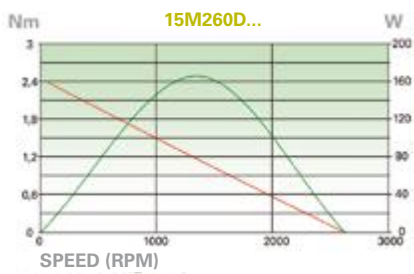
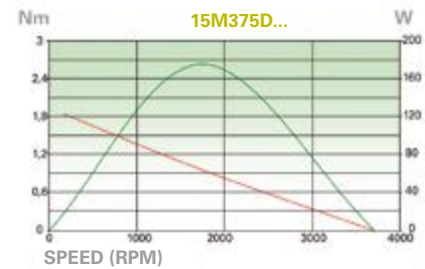
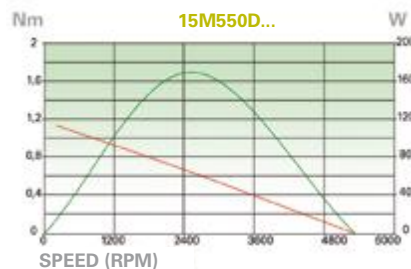
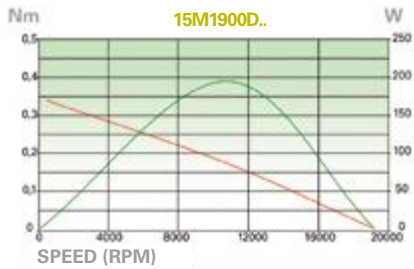

Models 20M...

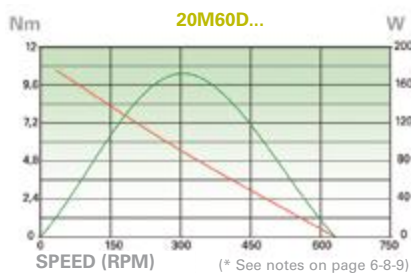
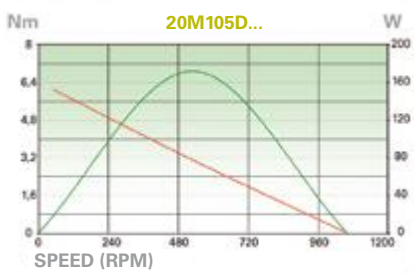
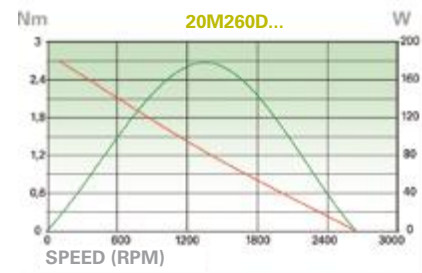
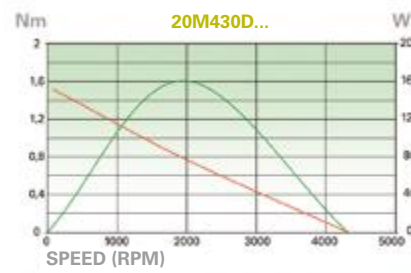
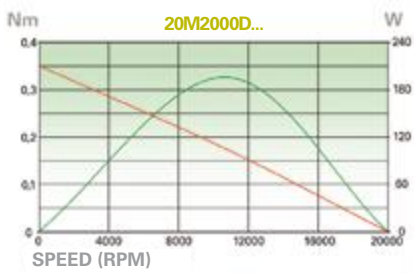

Models 28M...

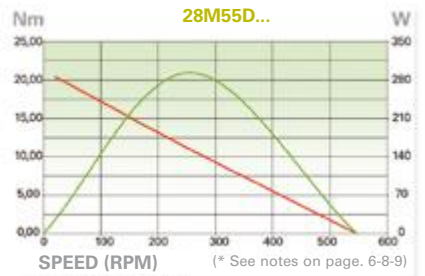
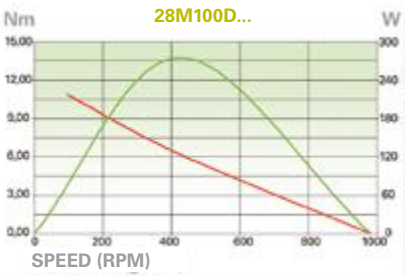
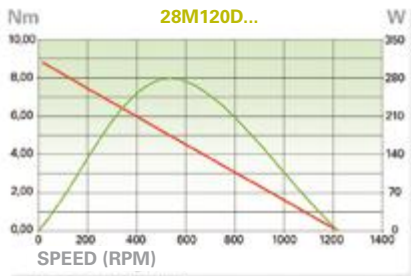
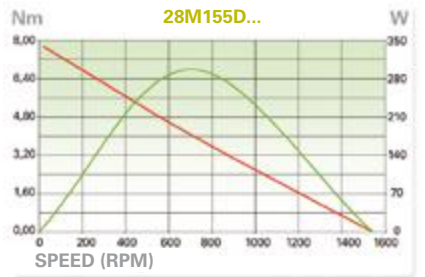
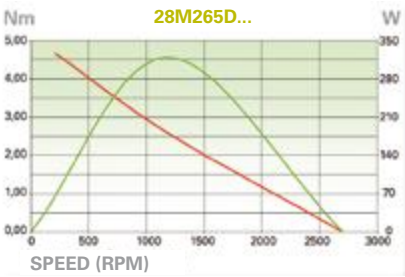
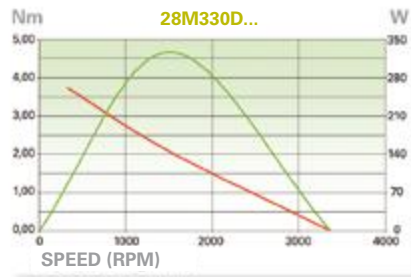
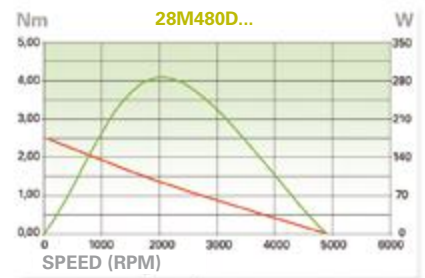
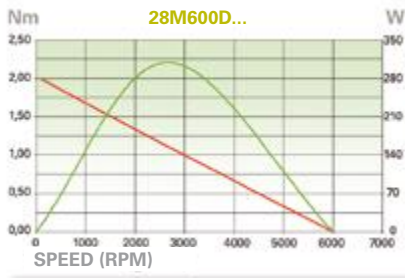

Models MM...

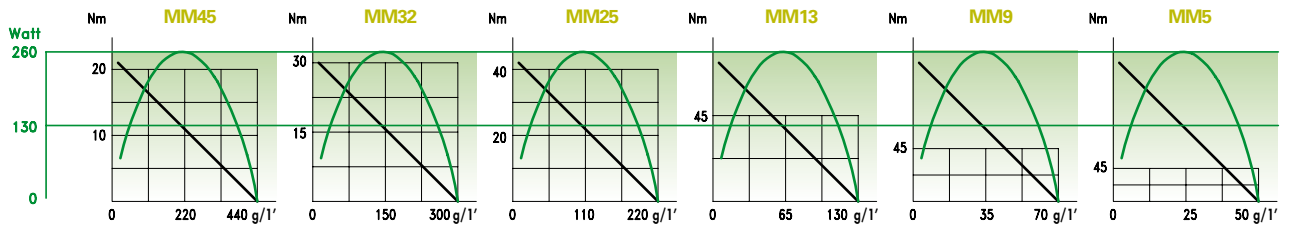

Models MN...

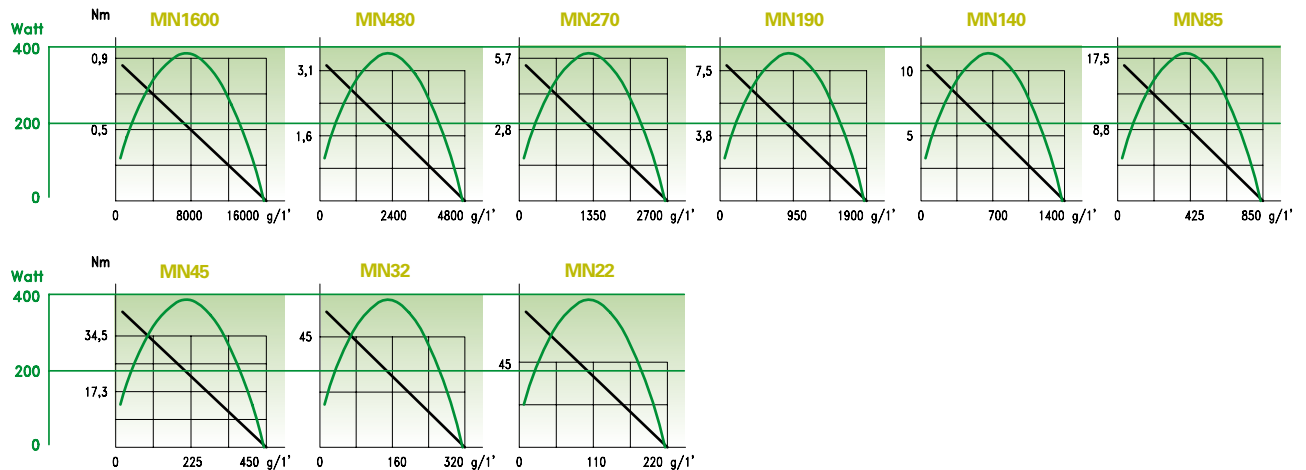

Models MO...

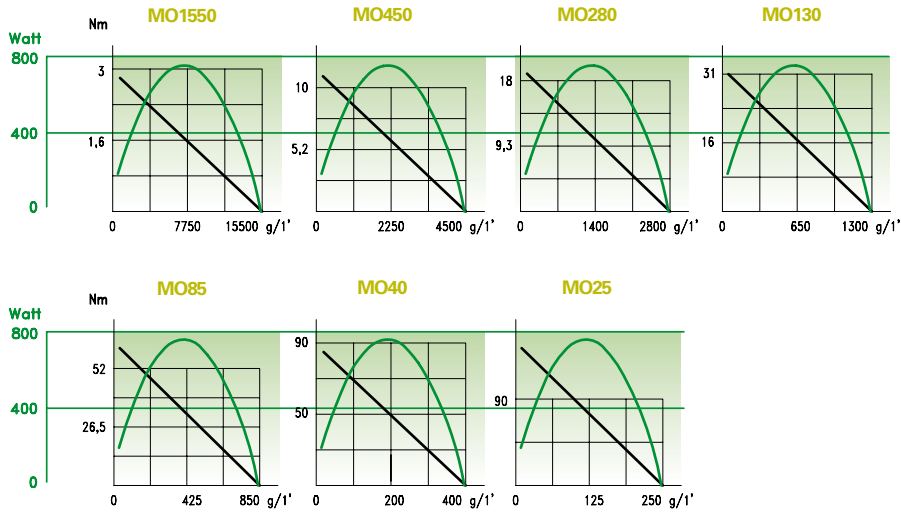

Reversible models

Models 15M...

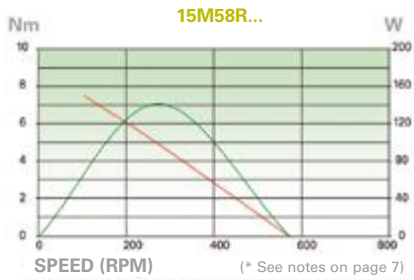
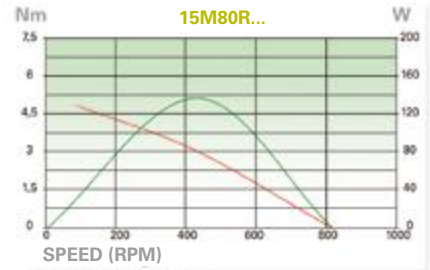
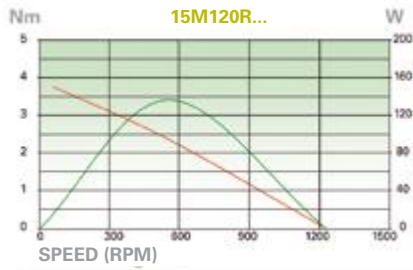
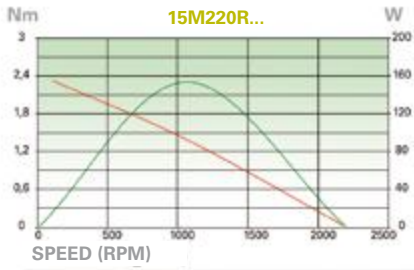
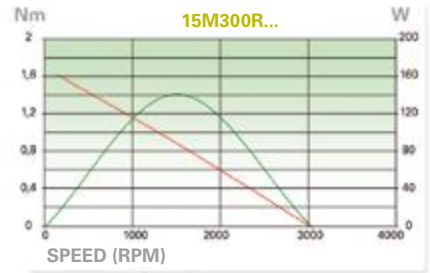
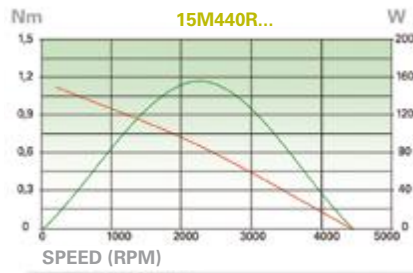
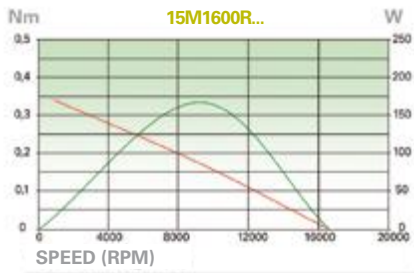

Models 20M...

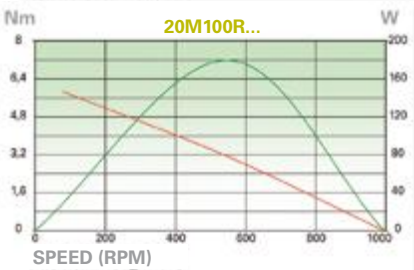
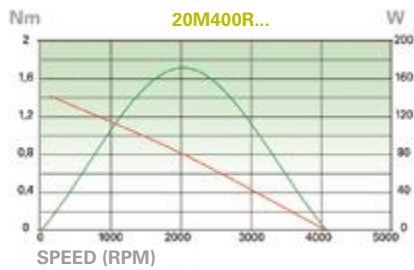
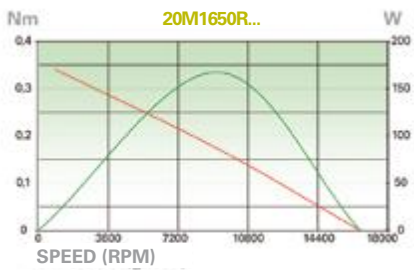

Models 28M...

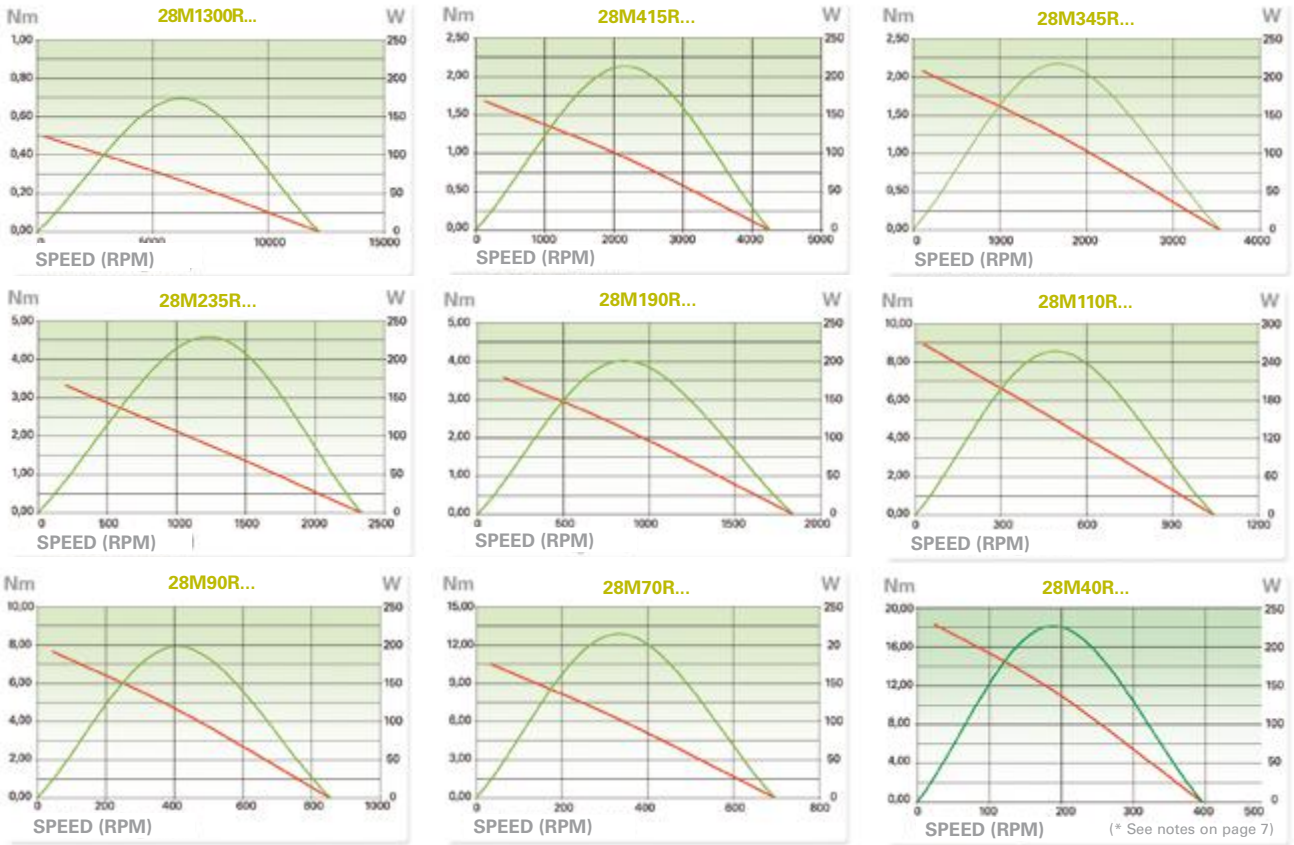

Models MM...

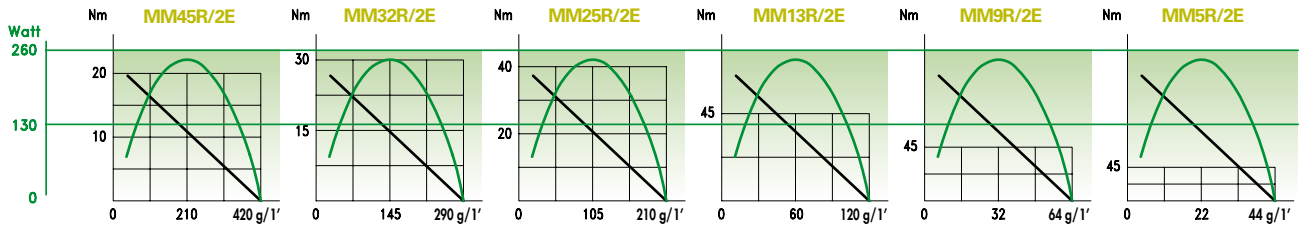

Models MN...

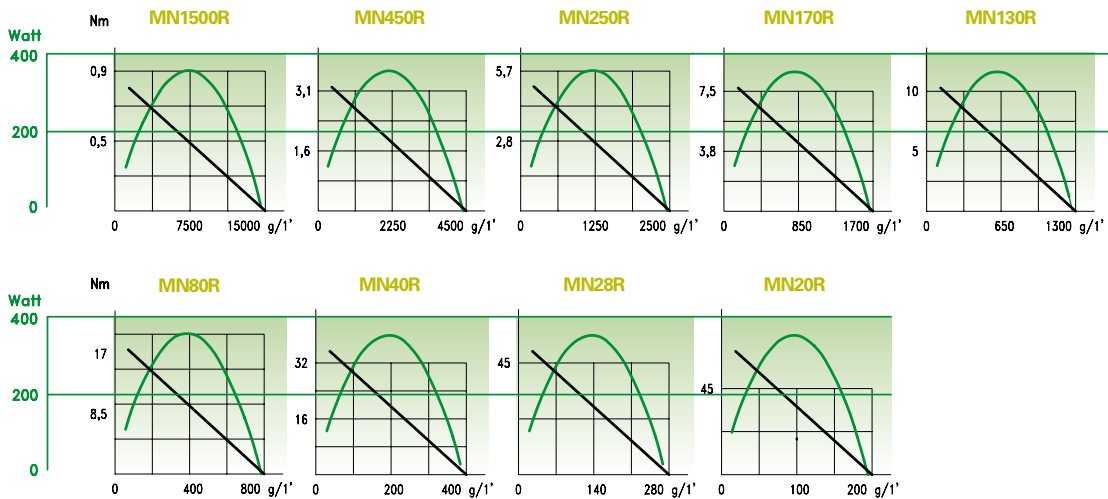

Models MO...

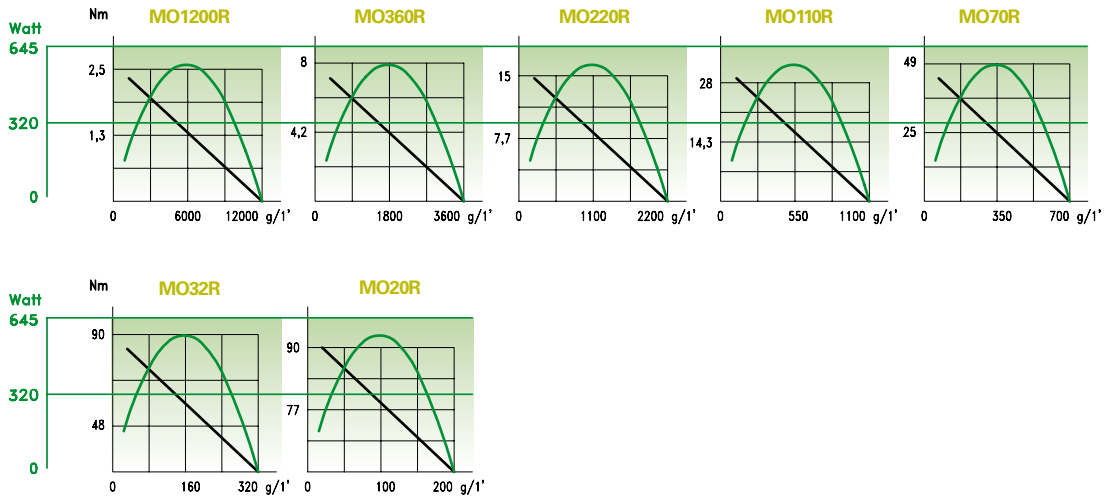

Accessories

Accessories for the use of air motors in drilling operations

- To use Fiam motors in drilling, burring, etc. operations it is necessary to order a motor with threaded output shaft 3/8" x 24 UNF (available only for motor with right hand rotation).

Keyed chucks

Sturdy chucks equipped with locking key to block the bit of the drill. The dimensions are expressed in millimeters (mm)

Chuck capacity (mm)	Drive type	Code
0 ÷ 6	3/8 x 24 UNF	650381006
0 ÷ 8	3/8 x 24 UNF	650381008



Chuck capacity (mm)	Drive type	Code
1 ÷ 10	3/8 x 24 UNF	650381010

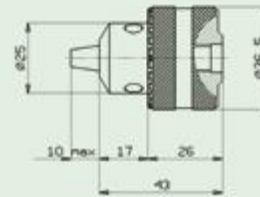

Collet chucks

The use of collets on motors with collet chuck permits to reduce the dimensions of encumbrance of the head of the drilling unit and to obtain the better accuracy in drilling.

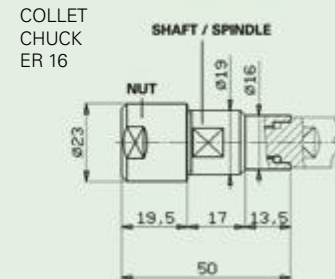
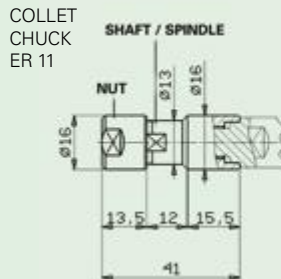

Collet chuck	Drive type	Code
ER 11	3/8x24 UNF	660449011
ER 16	3/8x24 UNF	660449010

Collets

They are to be chosen according to the diameter of the bit

* The locking capacity of the collet is referred to the diameter of the male shank of the bit

ER 11

ER 16



Collets ER 11

Capacity ø (mm)*	Code
1	660431010
1,5	660431015
2	660431020
2,5-3/32"	660431025
3	660431030
3,5-1/8"	660431035
4	660431040
4,5	660431045
5-3/16"	660431050
5,5	660431055
6	660431060
6,5-1/4"	660431065
7	660431070

Locking capacity of the collects

0,5 mm

Collets ER 16

Capacity ø (mm)*	Code
1	660441010
1,5	660441015
2	660441020
2,5-3/32"	660441025
3	660441030
4-1/8"	660441040
5-3/16"	660441050
6	660441060
7-1/4"	660441070
8-5/16"	660441080
9	660441090
10	660441100

Locking capacity of the collects

da 1 a 3 mm = 0,5 mm
oltre 3 mm = 1 mm

Accessories

• Flange bracket

Recommended to fix the motors onto machines/units

Code	Motor power	A mm	B mm	C mm	D mm	E mm
684011009	15M...	64,5	50	29	18	5,25
684011001	20M...	64,5	50	33,8	18	5,25
684011007	28M...	69,5	57	36	18	6,25
684011002	MM-MN	79,5	64	49	18	6,2
684011005	MO	129	105	65	35	10,2

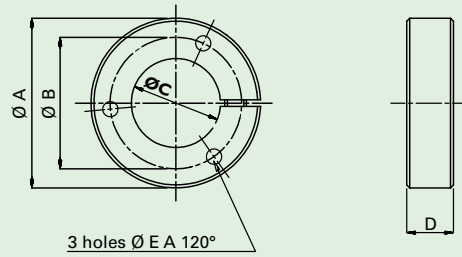

Fiam Utensili Pneumatici Spa

Viale Crispi 123
36100 Vicenza - Italy
Tel. +39.0444.385000
Fax +39.0444.385002

**Fiam France
Succursale**

73, cours Albert Thomas
69003 Lyon - France
Tel. +33 09 70 40 73 85

**Fiam España
Sucursal**

Travessera de Gràcia, 11, 5ª planta
08021 Barcelona, España
Tel. +34.636808112