

8V1320.00-2

1 General information

- Modular mechanical design using plug-in modules
- Integrated line filter
- Integrated or optional external braking resistor
- All connections are made using plug-in connectors
- Integrated electronic restart inhibit

2 Order data

Order number	Short description	Figure
	Servo drives	
8V1320.00-2	ACOPOS servo drive, 3x 400-480 V, 34 A, 16 kW, integrated line filter, braking resistor, DC bus power supply unit and electronic safe restart interlock	
	Optional accessories	
	Braking resistors	
8B0W0045H000.000-1	Braking resistor, 450 W, 50 R, IP20, terminals	
8B0W0045H000.001-1	Braking resistor, 450 W, 50 R, IP65, terminals	
8B0W0079H000.000-1	Braking resistor, 790 W, 33 R, IP20, terminals	
8B0W0079H000.001-1	Braking resistor, 790 W, 33 R, IP65, terminals	
	Plug-in modules	
8AC110.60-3	ACOPOS plug-in module, CAN interface	
8AC114.60-2	ACOPOS plug-in module, POWERLINK V2 interface	
8AC120.60-1	ACOPOS plug-in module, EnDat encoder and sine incremental encoder interface	
8AC121.60-1	ACOPOS plug-in module, HIPERFACE interface	
8AC122.60-3	ACOPOS plug-in module, resolver interface 10 kHz	
8AC123.60-1	ACOPOS plug-in module, incremental encoder and SSI absolute encoder interface	
8AC125.60-1	ACOPOS plug-in module, BiSS/SSI SinCos/SSI interface	
8AC125.60-2	ACOPOS plug-in module, BiSS encoder interface 5 V, baud rate 6.25 Mbit/s	
8AC125.61-2	ACOPOS plug-in module, BiSS encoder interface 12 V, baud rate 6.25 Mbit/s	
8AC126.60-1	ACOPOS plug-in module, EnDat 2.2 encoder interface	
8AC130.60-1	ACOPOS plug-in module, 8 digital I/O configurable in pairs as 24 V input or as output 400/100 mA, 2 digital outputs 2 A, order TB712 terminal block separately	
8AC131.60-1	ACOPOS plug-in module, 2 analog inputs ± 10 V, 2 digital I/Os configurable as 24 V input or output 45 mA, order terminal block TB712 separately!	
	Included in delivery	
	Shielding component sets	
8X0020.00-1	ACOPOS shielding components set for 8V1180.xxx-x and 8V1320.xxx-x	
	Terminal sets	
8X0002.00-1	ACOPOS accessories, plug set for 8V1180.00 and 8V1320.00 (3 phase)	

Table 1: 8V1320.00-2 - Order data

3 Technical data

Order number	8V1320.00-2
General information	
B&R ID code	0x1283
Slots for plug-in modules	4

Table 2: 8V1320.00-2 - Technical data

Order number	8V1320.00-2
Certifications	
CE	Yes
Functional safety ¹⁾	Yes
UL	cULus E225616 Power conversion equipment
EAC	Yes
KC	Yes
Mains connection	
Permissible network configurations	TT, TN ²⁾
Mains input voltage	3x 400 VAC to 480 VAC $\pm 10\%$
Frequency	50 / 60 Hz $\pm 4\%$
Installed load	Max. 30 kVA
Inrush current at 400 VAC	13 A
Switch-on interval	>10 s
Integrated line filter per EN 61800-3, category C3 ³⁾	Yes
Power dissipation at device nominal power without braking resistor	Approx. 800 W
DC bus connection	
DC bus capacitance	1645 μ F
24 VDC power supply	
Input voltage	24 VDC +25% / -20%
Input capacitance	40,000 μ F
Current consumption at 24 VDC ⁴⁾	
Mains input voltage applied	- ⁵⁾
Mains input voltage not applied	Max. 2.8 A + Current for the motor holding brake + Current on the 24 VDC output
DC bus power supply unit	
Switch-on voltage	455 VDC
24 VDC output	
Output voltage	
Mains input voltage applied	22 to 24 VDC
Mains input voltage not applied	16.7 to 30 VDC ⁶⁾
Output current	Max. 0.5 A
Motor connection	
Quantity	1
Continuous current ⁷⁾	34 A _{eff}
Reduction of continuous current depending on ambient temperature	
Mains input voltage: 400 VAC	
Switching frequency 5 kHz	No reduction
Switching frequency 10 kHz	No reduction ⁸⁾
Switching frequency 20 kHz	0.61 A _{eff} per °C (starting at 40°C)
Mains input voltage: 480 VAC	
Switching frequency 5 kHz	No reduction
Switching frequency 10 kHz	No reduction ⁸⁾
Switching frequency 20 kHz	0.61 A _{eff} per °C (starting at 25°C)
Reduction of continuous current depending on installation elevation	
Starting at 500 m above sea level	3.4 A _{eff} per 1000 m
Peak current	80 A _{eff}
Nominal switching frequency	10 kHz
Possible switching frequencies	5 / 10 / 20 kHz
Insulation stress of the connected motor per IEC TS 60034-25:2004 ⁹⁾	Limit value curve A
Max. motor cable length	25 m
Protective measures	
Overload protection	Yes
Short circuit and ground fault protection	Yes
Max. output frequency	598 Hz ¹⁰⁾
Terminal connection cross section	
Flexible and fine-stranded wires	
With wire end sleeves	0.5 to 6 mm ²
Approbation data	
UL/C-UL-US	20 to 8 AWG
CSA	20 to 8 AWG
Motor holding brake connection	
Response threshold for open circuit monitoring	Approx. 250 mA
Max. output current	1.5 A
Max. number of switching cycles	Unlimited since implemented electronically
Braking resistor	
Peak power int./ext.	14 / 40 kW
Continuous power int./ext.	0.4 / 8 kW ¹¹⁾
Minimum braking resistance (ext.)	15 Ω
Rated current of built-in fuse	12 A (fast-acting)

Table 2: 8V1320.00-2 - Technical data

Order number	8V1320.00-2
Limit switch and reference inputs	
Quantity	3
Circuit	Sink
Electrical isolation	
Input - ACOPOS	Yes
Input - Input	No
Input voltage	
Nominal	24 VDC
Maximum	30 VDC
Switching threshold	
Low	<5 V
High	>15 V
Input current at nominal voltage	Approx. 4 mA
Switching delay	Max. 2.0 ms
Modulation compared to ground potential	Max. ±38 V
Enable inputs	
Quantity	1
Circuit	Sink
Electrical isolation	
Input - ACOPOS	Yes
Input voltage	
Nominal	24 VDC
Maximum	30 VDC
Input current at nominal voltage	Approx. 30 mA
Switching threshold	
Low	<5 V
High	>15 V
Switching delay	
Enable 0 → 1, ready for PWM	Max. 100 µs
Enable 1 → 0, PWM off	Max. 2.0 ms
Modulation compared to ground potential	Max. ±38 V
OSSD signal connections ¹²⁾	Not permitted
Trigger inputs	
Quantity	2
Circuit	Sink
Electrical isolation	
Input - ACOPOS	Yes
Input - Input	No
Input voltage	
Nominal	24 VDC
Maximum	30 VDC
Switching threshold	
Low	<5 V
High	>15 V
Input current at nominal voltage	Approx. 10 mA
Switching delay	
Rising edge	52 µs ±0.5 µs (digitally filtered)
Falling edge	53 µs ±0.5 µs (digitally filtered)
Modulation compared to ground potential	Max. ±38 V
Electrical properties	
Discharge capacitance	3.1 µF
Energy efficiency (IE classification) ¹³⁾	
Efficiency data	IE2 (10,25) 0.8% IE2 (50,25) 0.8% IE2 (10,50) 1% IE2 (50,50) 1.1% IE2 (90,50) 1.3% IE2 (10,100) 1.8% IE2 (50,100) 2.1% IE2 (90,100) 2.6%
Nominal losses in standby mode	31.8 W
Operating conditions	
Permissible mounting orientations	
Hanging vertically	Yes
Horizontal, face up	Yes
Standing horizontally	No
Installation elevation above sea level	
Nominal	0 to 500 m
Maximum ¹⁴⁾	2000 m
Pollution degree per EN 61800-5-1	2 (non-conductive pollution)
Overvoltage category per EN 61800-5-1	II
Degree of protection per EN 60529	IP20

Table 2: 8V1320.00-2 - Technical data

Order number	8V1320.00-2
Ambient conditions	
Temperature	
Operation	
Nominal	5 to 40°C
Maximum ¹⁵⁾	55°C
Storage	-25 to 55°C
Transport	-25 to 70°C
Relative humidity	
Operation	5 to 85%
Storage	5 to 95%
Transport	Max. 95% at 40°C
Mechanical properties	
Dimensions	
Width	200 mm
Height	375 mm
Depth	234 mm
Weight	10.6 kg

Table 2: 8V1320.00-2 - Technical data

- 1) Achievable safety classifications (safety integrity level, safety category, performance level) are documented in the user's manual (section "Safety technology").
- 2) TT and TN power systems are commonly referred to as "Delta/Wye with grounded wye neutral" in the USA.
- 3) Limit values from EN 61800-3 C3 (second environment).
- 4) Current consumption depends on the respective configuration of the ACOPOS servo drive.
The inrush current is significantly higher than the value for current consumption and can be estimated according to the input capacitance.
- 5) If the mains input voltage is present (3x 400 VAC to 480 VAC $\pm 10\%$), the 24 VDC supply voltage for the ACOPOS servo drive is generated by the internal DC bus power supply unit, reducing the 24 VDC current consumption (I_{24VDC}) to 0.
- 6) If the mains input voltage (3x 400 VAC to 480 VAC $\pm 10\%$) is not present, the voltage on the 24 VDC output is generated from the 24 VDC power supply of the ACOPOS servo drive; in this case, it lies between the maximum permissible and the (reduced by a maximum of 2.5 V) minimum permissible 24 VDC power supply of the ACOPOS servo drive.
- 7) Valid under the following conditions: mains input voltage 400 VAC, nominal switching frequency, 40°C ambient temperature, installation elevation <500 m above sea level.
- 8) Value for the nominal switching frequency.
- 9) If necessary, the stress of the motor isolation system can be reduced by an additional externally wired dv/dt choke. For example, the RWK 305 three-phase dU/dt choke from Schaffner (www.schaffner.com) can be used. Important: Even when using a dv/dt choke, it is necessary to ensure that an EMC-compatible, low inductance shield connection is used!
- 10) The module's electrical output frequency (SCTRL_SPEED_ACT * MOTOR_POLEPAIRS) is monitored to protect against dual use in accordance with Regulation (EC) 428/2009 | 3A225. If the electrical output frequency of the module exceeds the limit value of 598 Hz uninterrupted for more than 0.5 s, then the current movement is aborted and error 6060 is output ("Power unit: Limit speed exceeded").
- 11) Continuous power refers to the maximum braking power the ACOPOS servo drive can exchange continuously. Depending on the application, the actual continuous power provided by the external braking resistor is limited by the rated current of fuse I_b (integrated in the ACOPOS servo drive), and the value of the external braking resistance R_{BR} .
- 12) OSSD (output signal switching device) signals are used to monitor signal lines for short circuits and cross faults.
- 13) The IE classification of the module is based on drive losses. This includes components such as EMC filters, etc. The efficiency data was determined at a switching frequency of 5 kHz. Classification is performed at 90% of the frequency and at 100% of the current. When operating the module in connection with an induction motor, the module is only permitted to be operated with a switching frequency of 5 kHz.
- 14) Continuous operation of ACOPOS servo drives at an installation elevation from 500 m to 2000 m above sea level is possible (taking the specified continuous current reductions into account).
- 15) Continuous operation of the ACOPOS servo drive at an ambient temperature of 40°C to max. 55°C is possible taking the specified reduction of continuous torque into account, but this results in premature aging of components.

4 Status indicators

ACOPOS servo drives are equipped with three LEDs for direct diagnostics:

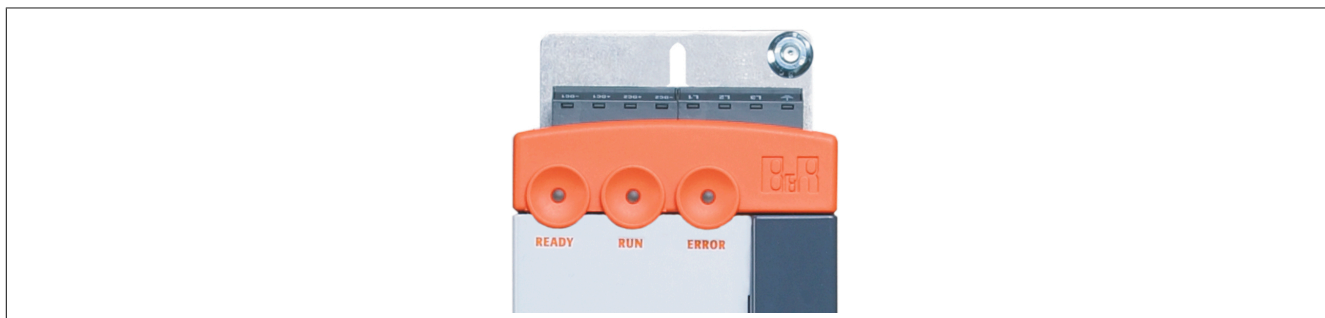

Figure 1: ACOPOS servo drive indicators

LED status indicators

Label	Color	Function	Description	
READY	Green	Ready	Solid green	The module is operational and the power stage can be enabled (operating system present and booted, no permanent or temporary errors).
			Blinking green ¹⁾	The module is not ready for operation. <u>Examples:</u> <ul style="list-style-type: none"> No signal on one or both enable inputs DC bus voltage outside the tolerance range Overtemperature on the motor (temperature sensor) Motor feedback not connected or defective Motor temperature sensor not connected or defective Overtemperature on the module (IGBT junction, heat sink, etc.) Disturbance on network
RUN	Orange	Run	Solid orange	The module's power stage is enabled.
ERROR	Red	Error	Solid red ¹⁾	There is a permanent error on the module. <u>Examples:</u> <ul style="list-style-type: none"> Permanent overcurrent Invalid data in EPROM

Table 3: ACOPOS servo drive - LED status indicators

1) Firmware V2.130 and later.

If no LED is lit up, the ACOPOS servo drive is not supplied with 24 VDC mains voltage.

Danger!

After switching off the device, wait for the DC bus to discharge for at least five minutes. To avoid a hazard, the current voltage on the DC bus must be measured with a suitable measuring instrument and less than 42 VDC before starting work. An unlit operating LED does not indicate that the device is de-energized!

4.1 Status changes when starting up the operating system loader

The following intervals are used for the LED status indicators:

Width of box: 125 ms

Repeats after: 3000 ms

Status	LED	Display
1. Boot procedure for base hardware active	Green	[Green box]
	Orange	[Orange box]
	Red	[Red box]
2. Network plug-in module configuration active	Green	[Green box]
	Orange	[Orange box]
	Red	[Red box]
3. Waiting for network telegram	Green	[Green box]
	Orange	[Orange box]
	Red	[Red box]
4. Network communication active	Green	[Green box]
	Orange	[Orange box]
	Red	[Red box]

Table 4: Status changes when starting up the operating system loader

Error status with reference to CAN plug-in module AC110

Status	LED	Display																							
Invalid hardware ID ¹⁾	Green																								
	Orange																								
	Red	■	■	■	■	■	■	■	■	■	■	■	■	■	■	■	■	■	■	■	■	■	■	■	■
Boot error in CAN base hardware	Green																								
	Orange																								
	Red	■	■	■	■	■	■	■	■	■	■	■	■	■	■	■	■	■	■	■	■	■	■	■	
Bus off	Green																								
	Orange																								
	Red	■	■	■	■	■	■	■	■	■	■	■	■	■	■	■	■	■	■	■	■	■	■	■	
The CAN station number is 0.	Green																								
	Orange																								
	Red	■	■	■	■	■	■	■	■	■	■	■	■	■	■	■	■	■	■	■	■	■	■	■	

Table 5: Error status with reference to CAN plug-in module AC110

- 1) Possible errors:
- The ACOPOS servo drive is defective.
 - The plug-in module is defective
 - The plug-in module is not connected properly in the slot.

Error status with reference to POWERLINK V2 plug-in module AC114

Status	LED	Display																							
Invalid hardware ID ¹⁾	Green	■	■	■	■	■	■	■	■	■	■	■	■	■	■	■	■	■	■	■	■	■	■	■	
	Orange																								
	Red	■	■	■	■	■	■	■	■	■	■	■	■	■	■	■	■	■	■	■	■	■	■	■	
Boot error in POWERLINK base hardware	Green	■	■	■	■	■	■	■	■	■	■	■	■	■	■	■	■	■	■	■	■	■	■	■	
	Orange																								
	Red	■	■	■	■	■	■	■	■	■	■	■	■	■	■	■	■	■	■	■	■	■	■	■	
Error booting the AC114-ARM	Green	■	■	■	■	■	■	■	■	■	■	■	■	■	■	■	■	■	■	■	■	■	■	■	
	Orange																								
	Red	■	■	■	■	■	■	■	■	■	■	■	■	■	■	■	■	■	■	■	■	■	■	■	
The POWERLINK station number is 0.	Green	■	■	■	■	■	■	■	■	■	■	■	■	■	■	■	■	■	■	■	■	■	■	■	
	Orange																								
	Red	■	■	■	■	■	■	■	■	■	■	■	■	■	■	■	■	■	■	■	■	■	■	■	

Table 6: Error status with reference to POWERLINK V2 plug-in module AC114

- 1) Possible errors:
- The ACOPOS servo drive is defective (plug-in module not detected).
 - The plug-in module is defective
 - The plug-in module is not connected properly in the slot.
 - The plug-in module works but is not automatically detected by the ACOPOS servo drive (old bootstrap loader).

5 Dimension diagram and installation dimensions

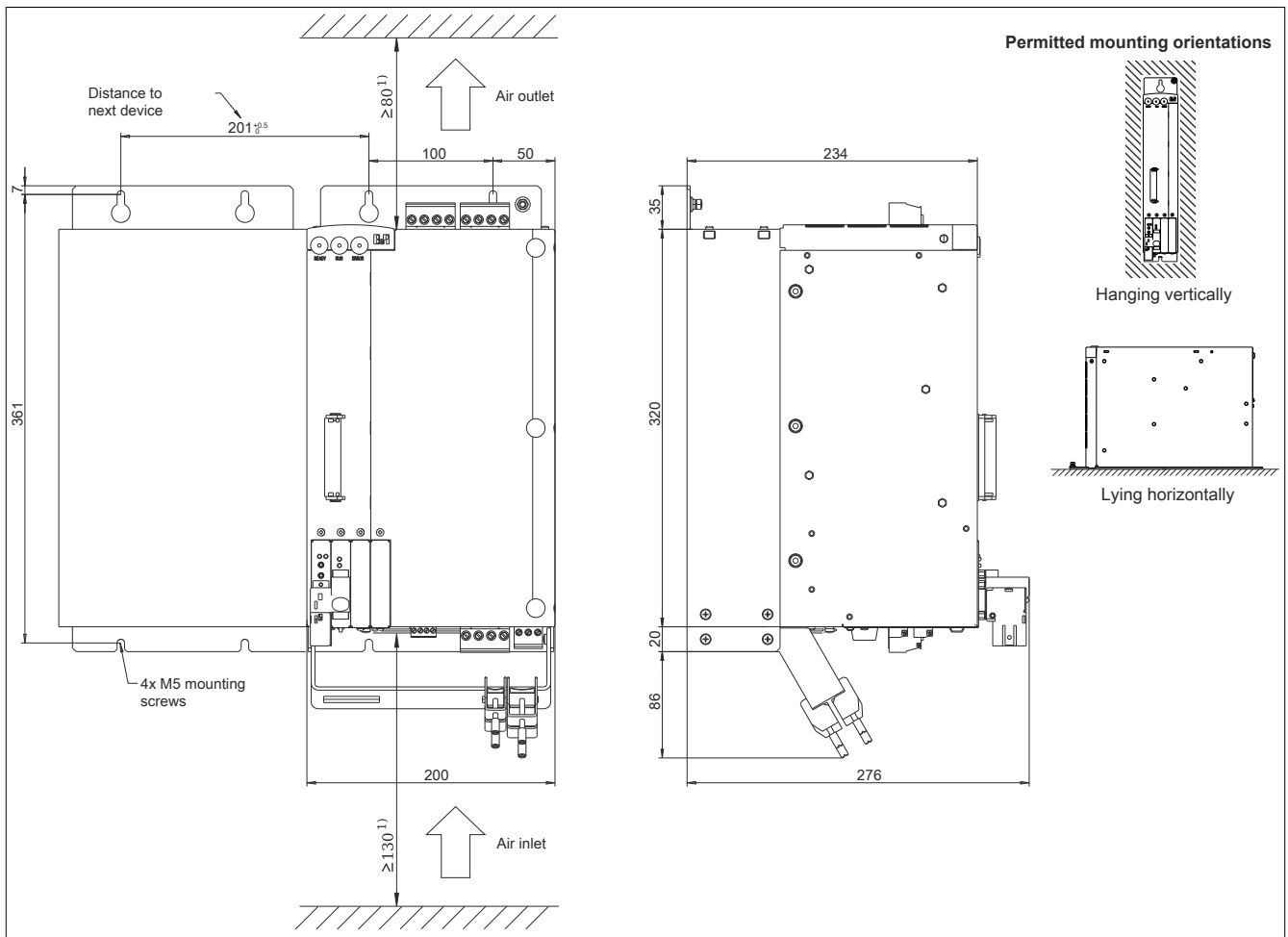

Figure 2: Dimension diagram and installation dimensions

- 1) For proper air circulation, at least 80 mm clearance must be available above and below the ACOPOS servo drive. At least 130 mm free space is required under the ACOPOS servo drive to prevent cabling problems.

6 Wiring

Pinout overview

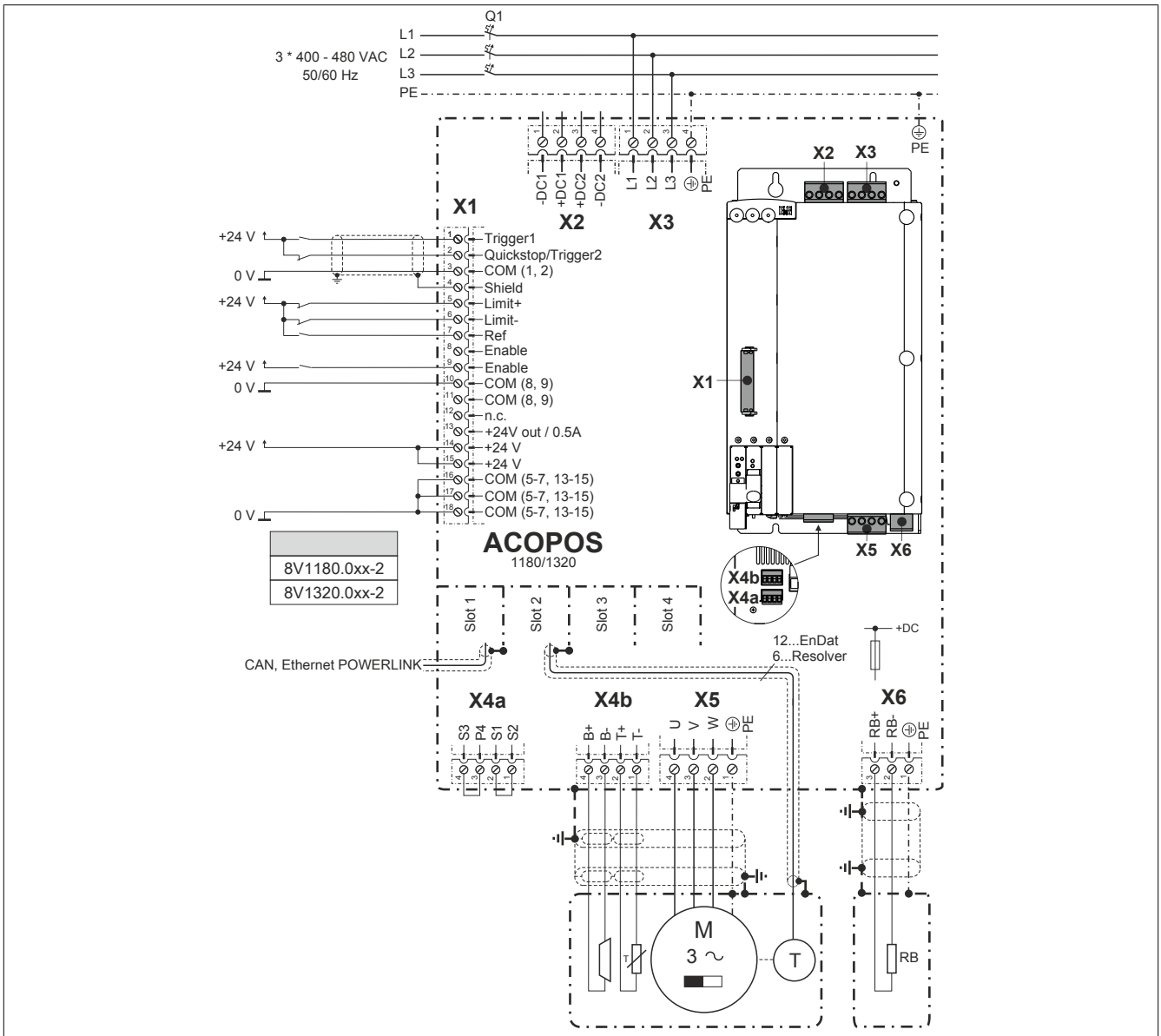

Figure 3: ACOPOS 1180, 1320 - Pinout overview

6.1 X1 - Pinout

X1	Pin	Name	Function
	1	Trigger1	Trigger 1
	2	Quickstop/Trigger2	Quickstop/Trigger2
	3	COM (1, 2)	Trigger 1, Quickstop/Trigger 2 0 V
	4	Shield	Shield
	5	Limit+	Positive HW limit
	6	Limit-	Negative HW limit
	7	Ref	Reference switch
	8	Enable ¹⁾	Enable
	9	Enable ¹⁾	Enable
	10	COM (8, 9)	Enable 0 V
	11	COM (8, 9)	Enable 0 V
	12	---	---
	13	+24V out / 0.5A	+24 V output / 0.5 A
	14	+24 V	+24 V supply
	15	+24 V	+24 V supply
	16	COM (5-7, 13-15)	0 V supply
	17	COM (5-7, 13-15)	0 V supply
	18	COM (5-7, 13-15)	0 V supply
The following connections are linked with each other internally in the device: <ul style="list-style-type: none"> • Pin 8 --> Pin 9 (Enable) • Pin 10 --> Pin 11 (Enable 0 V) • Pin 14 --> Pin 15 (Supply +24 V) • Pin 16 --> Pin 17 --> Pin 18 (Supply 0 V) 			

Table 7: X1 - Pinout

1) The wiring is not permitted to exceed a total length of 30 m.

Information:

To obtain a defined reference of ground to ground potential, B&R recommends grounding the COM connections (5-7, 13-15) on connector X1.

6.2 X2 - Pinout

X2	Pin	Name	Function
	1	-DC1	U DC bus -
	2	+DC1	U DC bus +
	3	+DC2	U DC bus +
	4	-DC2	U DC bus -

Table 8: X2 - Pinout

6.3 X3 - Pinout

Danger!

Servo drives are not permitted to be operated directly on IT power systems and corner-grounded TN-S power systems with protective ground conductor!

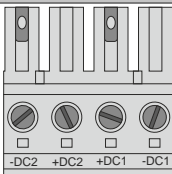
X3	Pin	Name	Function
	1	L1	Power mains connection L1
	2	L2	Power mains connection L2
	3	L3	Power mains connection L3
	4	PE	Protective ground conductor

Table 9: X3 - Pinout

6.4 X4a, X4b - Pinout

X4a	Pin	Description	Function
	1	S2 ¹⁾	Enabling, power supply of external holding brake (+)
	2	S1 ¹⁾	Enabling of external holding brake (+)
	3	S4	Enabling, power supply of external holding brake (-)
	4	S3	Enabling of external holding brake (-)

Table 10: X4a - Pinout

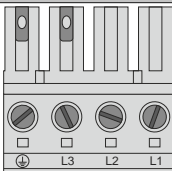
- 1) If the holding brake is connected via an additional external relay contact (ground-in e.g. via connections S1/S2) instead of only via the internal transistor, then the internal quenching circuit has no effect! In this case, the customer must make sure that neither the relay contact nor the braking coil are damaged when switching off the brake. This can be done by interconnecting the coil or - better still - interconnecting the contact with a quenching circuit.

X4b	Pin	Description	Function
	1	T-	Temperature sensor -
	2	T+	Temperature sensor +
	3	B- ¹⁾	Brake -
	4	B+ ¹⁾	Brake +

Table 11: X4b - Pinout

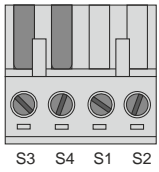
- 1) If the holding brake is connected via an additional external relay contact (ground-in e.g. via connections S1/S2) instead of only via the internal transistor, then the internal quenching circuit has no effect! In this case, the customer must make sure that neither the relay contact nor the braking coil are damaged when switching off the brake. This can be done by interconnecting the coil or - better still - interconnecting the contact with a quenching circuit.

Danger!

The connections for the motor temperature sensors and the motor holding brake are safely isolated circuits. These connections are therefore only permitted to be connected to devices or components that have sufficient isolation per IEC 60364-4-41 or EN 61800-5-1.

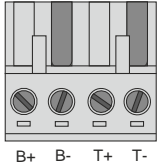
Caution!

If B+ and B- are swapped when connecting the permanent magnet holding brakes, then the brakes cannot be opened! ACOPOS servo drives cannot determine if a holding brake is connected with reverse polarity!

6.4.1 Wiring the connections for the motor holding brake

The power supply, enabling and monitoring of the output for the motor holding brake can be carried out in three different ways via the wiring of connector X4a:

	Figure	Description
1		<ul style="list-style-type: none"> • Power supply: Internal via the ACOPOS servo drive • Enabling: Internal via the ACOPOS servo drive • Monitoring: Internal via the ACOPOS servo drive <p>Jumpers must be placed between connections S1 and S2 as well as S3 and S4 on connector X4a. ¹⁾</p>
2		<ul style="list-style-type: none"> • Power supply: Internal via the ACOPOS servo drive • Enabling: Possible internally by the ACOPOS servo drive and externally by dry contacts ²⁾ • Monitoring: Internal via the ACOPOS servo drive <p>Information: ACOPOS-internal monitoring must be configured according to the requirements of the application. ³⁾</p>
3		<ul style="list-style-type: none"> • Power supply: External • Enabling: External • Monitoring: External <p>Information: ACOPOS-internal monitoring cannot be used here; it must therefore be disabled using software. ⁴⁾</p>

Table 12: Enabling the external holding brake

- 1) The two jumpers are already wired on connector X4a supplied with ACOPOS servo drives.
- 2) External dry contacts can be connected between S1 and S2 and between S3 and S4. This makes it possible to enable the holding brake via external safety circuits independently of the control integrated in the ACOPOS servo drive.
- 3) Configuration takes place using ParID 90 (1 ... Internal monitoring active, 5 ... Internal monitoring not active).
- 4) Disabling takes place using ParID 90 (5 ... Internal monitoring not active).

6.5 X5 - Pinout

X5	Pin	Name	Function
	1	PE	Protective ground conductor
	2	W	Motor connection W
	3	V	Motor connection V
	4	U	Motor connection U

Table 13: X5 - Pinout

6.6 X6 - Pinout

X6	Pin	Name	Function
	1	PE	Protective ground conductor
	2	RB-	Braking resistor -
	3	RB+	Braking resistor +

Table 14: X6 - Pinout

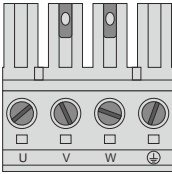
6.7 Additional protective ground connection (PE)

The protective ground conductor is connected to the M5 threaded bolt provided using a cable lug.

Figure	Pin	Name	Function
	---	PE	Protective ground conductor
Terminal cross sections Cable lug for M5 threaded bolt		[mm ²] 0.25 - 16	AWG 23 - 5

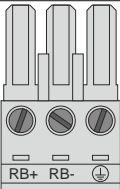
Table 15: Protective ground connection (PE) - ACOPOS

Danger!

Before turning on the servo drive, make sure that the housing is properly connected to ground (PE rail). The ground connection must be established even when testing the drive or operating it for a short time!

6.8 Input/output circuit diagram

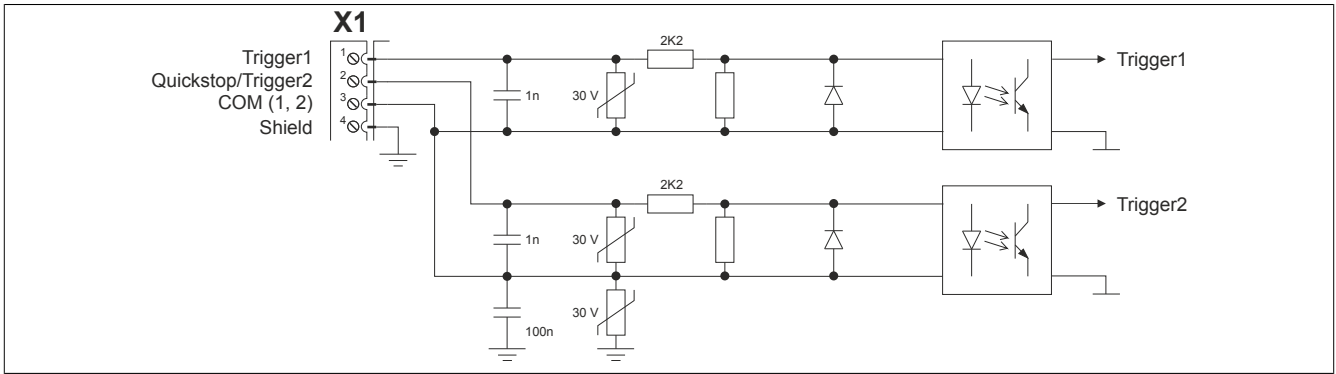

Figure 4: Trigger

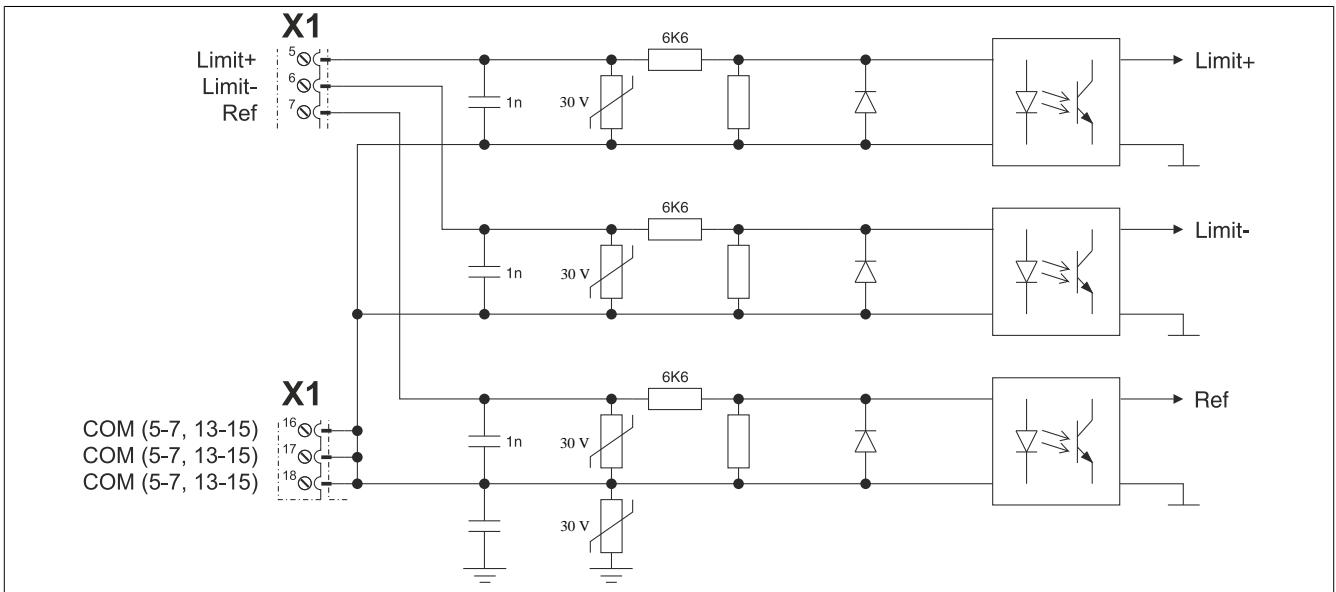

Figure 5: Limit

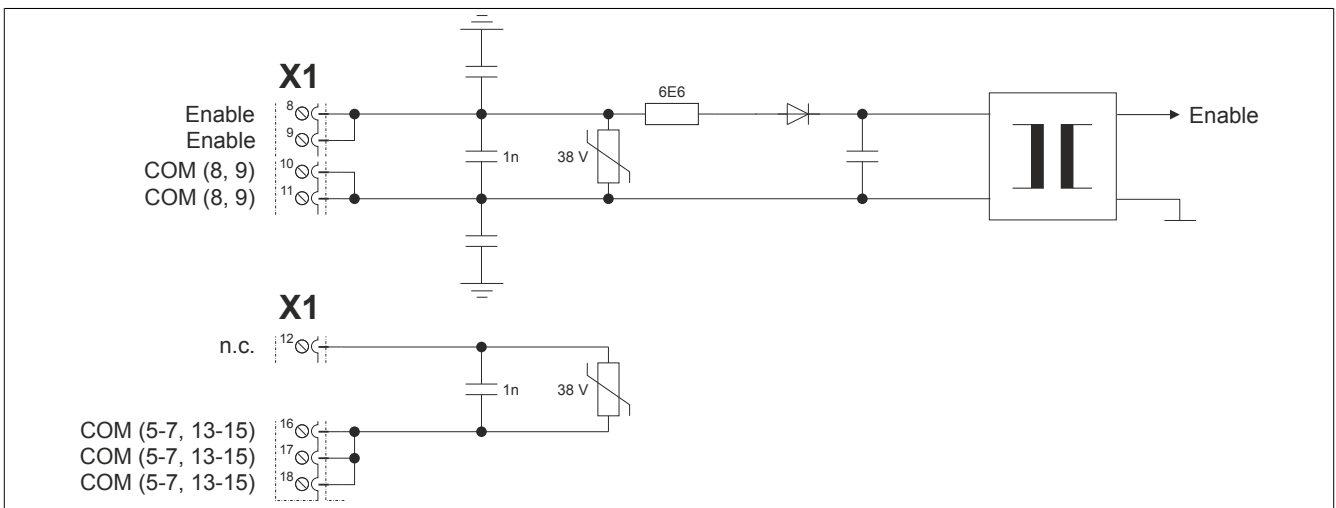

Figure 6: Enable

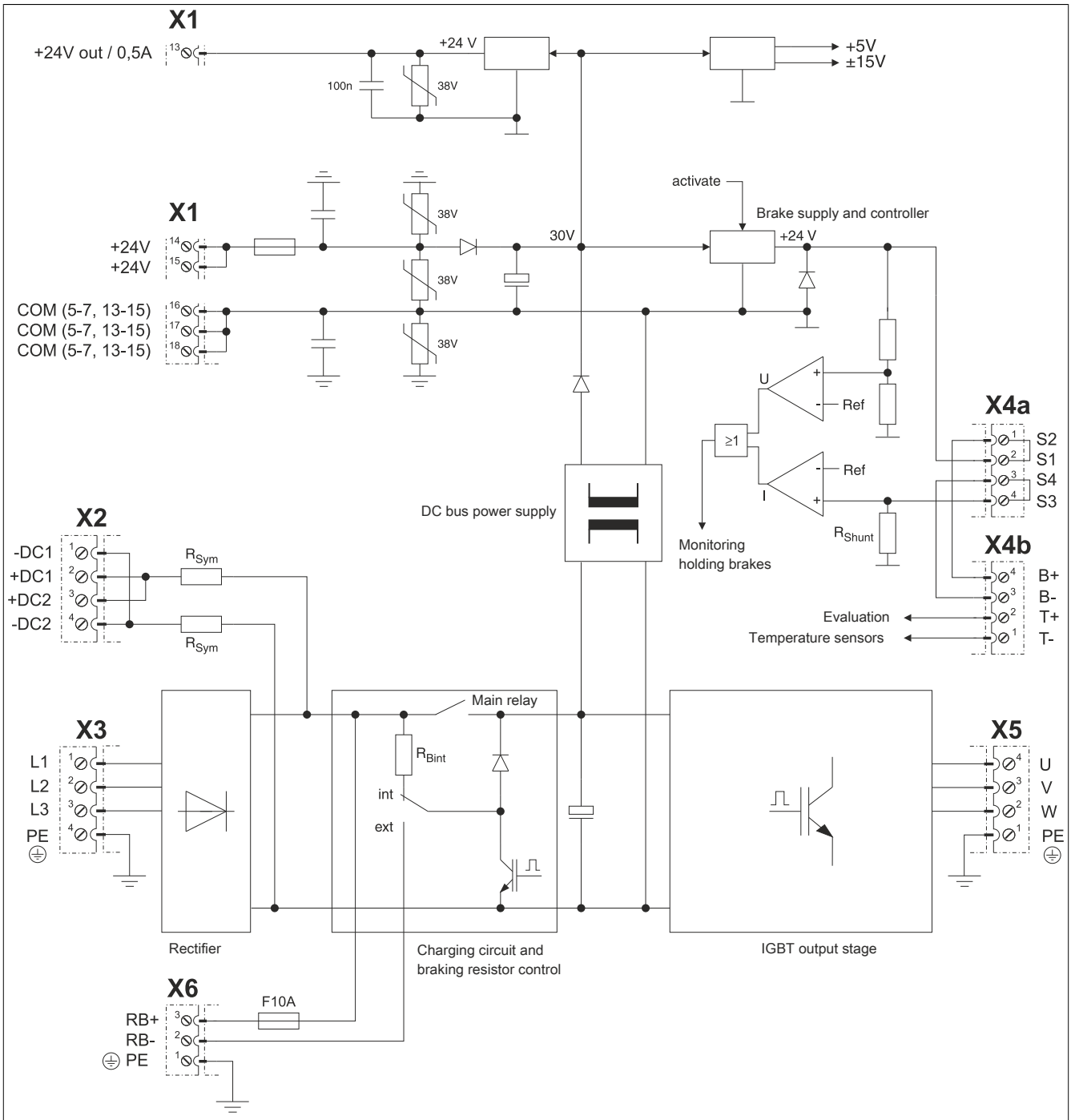

Figure 7: Input/output circuit diagram - ACOPOS 1180, 1320