



Metal wear debris sensor

Monitoring critical systems

aerospace
climate control
electromechanical
filtration
fluid & gas handling
hydraulics
pneumatics
process control
sealing & shielding



ENGINEERING YOUR SUCCESS.

Detecting system wear before catastrophic failure occurs to system components

Parker's Kittiwake latest generation of metal wear debris sensors provides unbeatable detection performance for both ferrous and non-ferrous metals

It is known in the market that particles result from wear processes in hydraulic and lubrication systems. It is imperative to know, not just the number of particles which pass through your system, but also the size and metallic composition. The latest generation of our metal wear debris sensors goes beyond normal protection systems, offering real-time monitoring of the contamination in the system. This allows system users or service organizations to take immediate action on the first indication of change, thereby preventing all types of failures to system components.

System Safety and Reliable operation by putting the system users or service organization in control

The Parker Kittiwake Metal Wear Debris sensor measures particles sizes from 40 micron to over 1000 micron, using proven inductive coil technology, making it suitable for continuous measurement of wear debris in a hydraulic and lubrication systems. Smart algorithms provide information about the particle size distribution count, differentiating between ferrous and non-ferrous wear particles. Our DebrisScan software puts the user in control by offering a customized communication between the metal wear debris sensor and main system controller.

The severity of problems increases with the escalation in the production of larger wear debris particles

With both digital and analogue outputs, the metal wear debris sensor can be easily integrated into existing condition monitoring and operating systems. Whether it's validating the health of the system or alerting wear patterns, the sensor provides instant information, completing existing laboratory oil analysis programmes and helping the user make informed maintenance planning decisions

Proven Technologies for demanding industries

Parker Kittiwake Metal Wear Debris Sensors are applied in a wide variety of demanding industries like:

- Oil & Gas market Top Drives, Mud Pumps
- Marine propulsion systems
- Wind Turbine gear boxes
- Industrial Power Train Drives



Parker Kittiwake Advantages

- Robust design of sensor with improved IP67 rating
- Wide detection range of particle sizes
- DebrisScan software for system-tailored communication between sensor and system
- Ethernet and RS485 communication protocols
- ATEX certified version (on request)
- ½ "BPS connections for quick and easy installation
- Other port sizes are on request

Maximize your pre-warning time before irreversible damage occurs



Examples of damaged gear wheel and roller bearing

- Avoid unexpected standstill of systems
- Extend life time of system components
- Maximize system efficiency
- Lower Cost of Ownership thanks to predictable maintenance

Effective integration of wear particle detection contributes to avoid unexpected system failure

Interfaces

The MWDS supports the following interfaces:

- Modbus RTU over RS485
- Modbus over TCP/IP
- CANopen (please contact Parker Kittiwake)
- 4-20mA outputs (Indications of Particles per Minute and Mass per Hour)
- Alarm Line

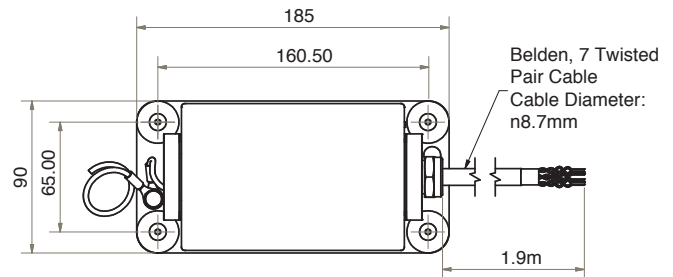

Specification

Ambient Temperature:	-20 to 70°C (-4 to 158°F)
Analogue Outputs:	2 x opto isolated 4 - 20 mA, 1 x alarm contacts (0.1 A max)
Communications:	Modbus over RS485 and TCP / IP*
Connections:	1/2"BSPP female
Detection:	> 40 micron (0.04 mm) [0.00157 inch] ferrous metal
Output:	> 135 micron (0.135 mm) [0.0531 inch] non-ferrous metal Simultaneous quantification of metallurgical composition and size category of particles in the fluid
Fluid Compatibility:	Petroleum, synthetic oils and water / oil emulsions
Fluid Temperature:	-20 to 85°C (-4 to 185°F)
Flow Rate:	0.3 - 1.9 ms-1
Sensor Bore:	Diameter 10 mm, length 120 mm
Max Fluid Pressure:	20 bar (290 psi)
Max Fluid Viscosity:	500 cSt
Power Supply:	18 - 30 V DC
Protection:	IP67
Weight:	3 kg

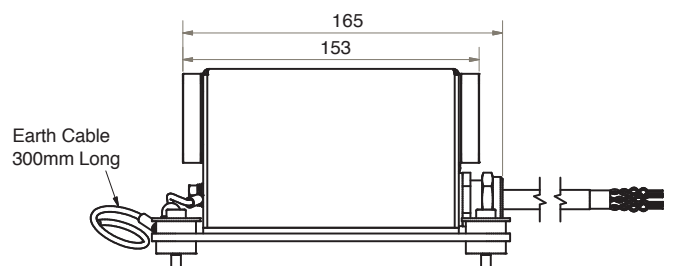
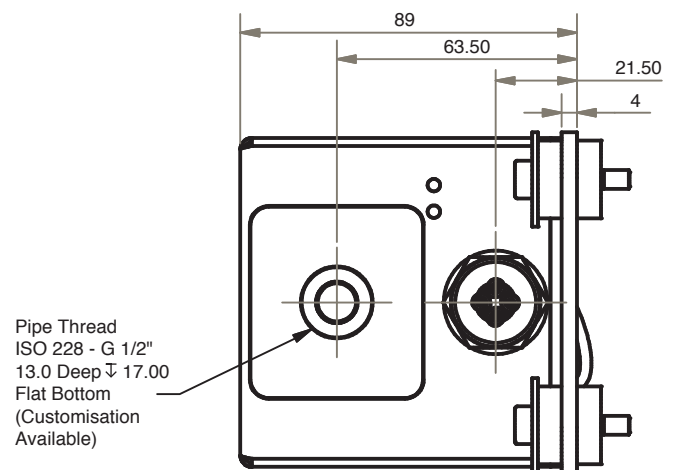

*Contact Parker Kittiwake for enquiries about CAN

Ordering information

Product Code	Description
FGK19567PA	Metallic Wear Debris Sensor

All sensors come complete with software for data downloading and trending. Contact Kittiwake for information about the wide range of installation accessories and alternative options that are available to suit your specific application.

