

Mechanical Installation

IMPORTANT Read Appendix B: "Certification" before installing this unit. Refer to "Installation Drawings", page 3-75 for further information. Note the additional information for Frame 6 and Frame H at the end of this Chapter.

Unpacking the Drive

Caution

The packaging is combustible and this action may produce lethal toxic fumes.

Save the packaging in case of return. Improper packaging can result in transit damage.

Frame H Packaging

Large drives (Frame H) are supplied in special packaging bolted to a pallet with removable sides. Remove all fixings from the pallet.

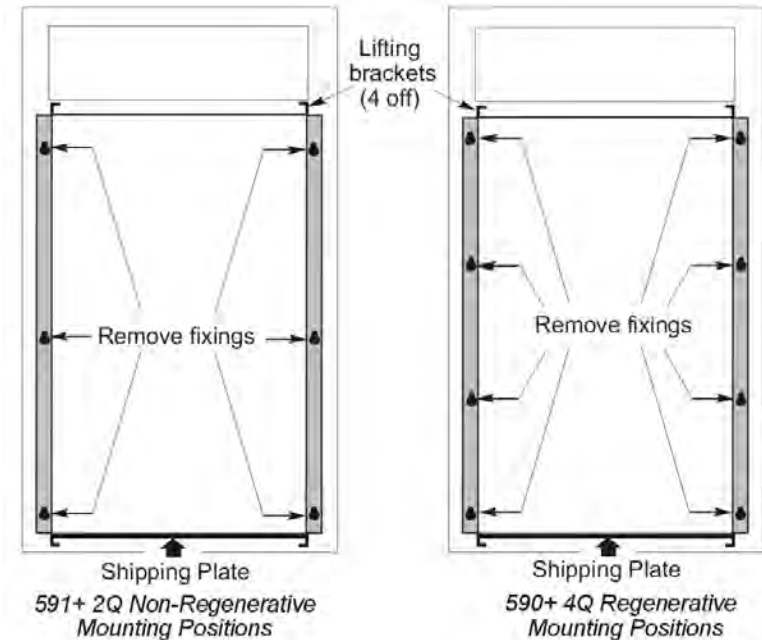

Figure 3-1 Lifting Details (Frame H)

Lifting the Drive

Use a safe and suitable lifting procedure when moving the drive. Never lift the drive by its terminal connections. Prepare a clear, flat surface to receive the drive before attempting to move it. Do not damage any terminal connections when putting the drive down.

Frame 4 & 5 drives have lifting eyes and a shipping plate fitted to the base to enable the drive to be lifted into position, or to be set-on-end by a forklift. Remove the shipping plate before wiring the power terminals.

Frame H drives require the following:

- The drive is supplied with a lifting bracket fitted to each corner for hoisting. Remove the brackets when the drive is in its final position, however, **the bracket fixings MUST be re-fitted**. Refer to Appendix E: "Technical Specifications" - Termination Tightening Torques (Frame H).

- A shipping plate is fitted to the base to enable the drive to be set-on-end by a forklift. Remove the plate before wiring the power terminals.

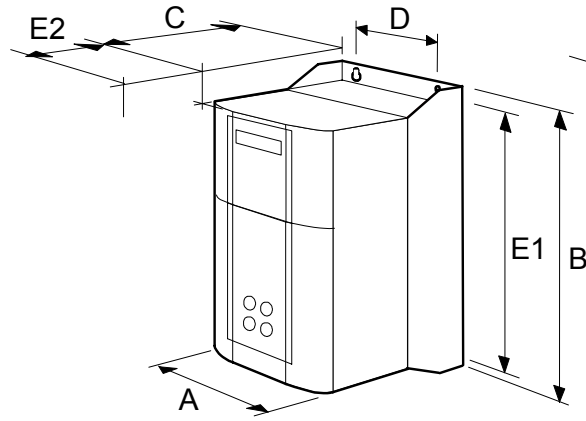

15A - 35A
Frame 1

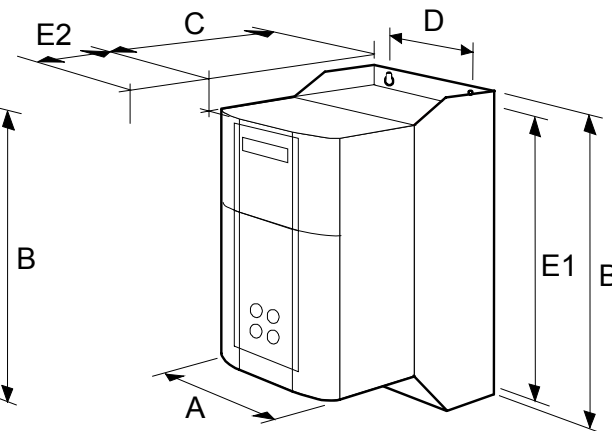

40A - 165A
Frame 2

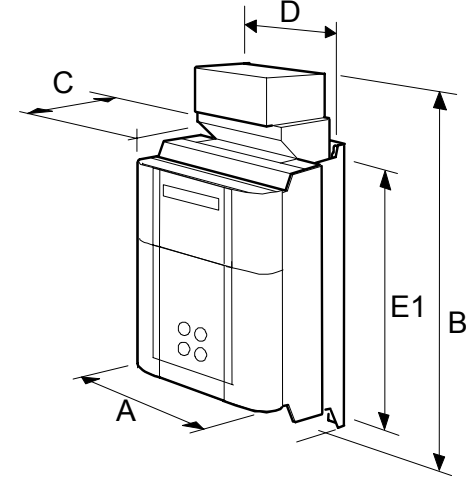

180A - 270A
Frame 3

Boxed (KG)	Current Rating (A)	Weight in Kg (lbs)	Overall Dimensions			Fixing Centres	
			A	B	C	D	E1
L51CM W31CM H35CM 7	15 - 35	6.4 (14)	200 (7.9)	375 (14.8)	220 (8.7)	140 (5.5)	360 (14.2)
L54CM W31CM H42CM 12	40 - 165	10.5 (23)	200 (7.9)	434 (17.1)	292 (11.5)	140 (5.5)	418 (16.5)
L62CM W44CM H38CM 19	180	20 (44)	250 (9.8)	485 (19.1)	234 (9.2)	200 (7.9)	400 (15.7)
L63CM W44CM H38CM 22	270	20 (44)	300 (11.8)	485 (19.1)	234 (9.2)	200 (7.9)	400 (15.7)

Dimensions are in millimetres (inches)
Refer to "Installation Drawings", page 3-75.

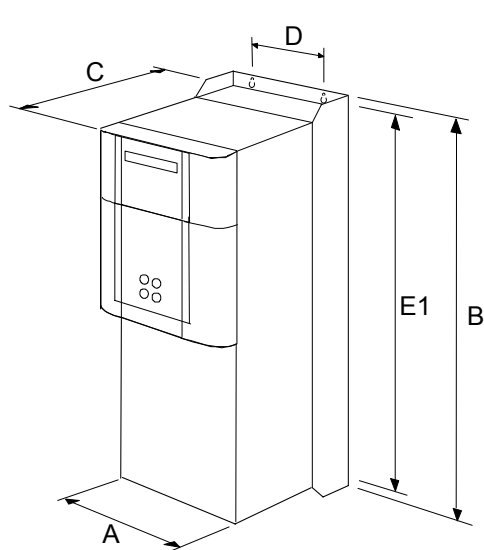

380A - 830A
Frame 4
 (vent kit assemblies not shown)

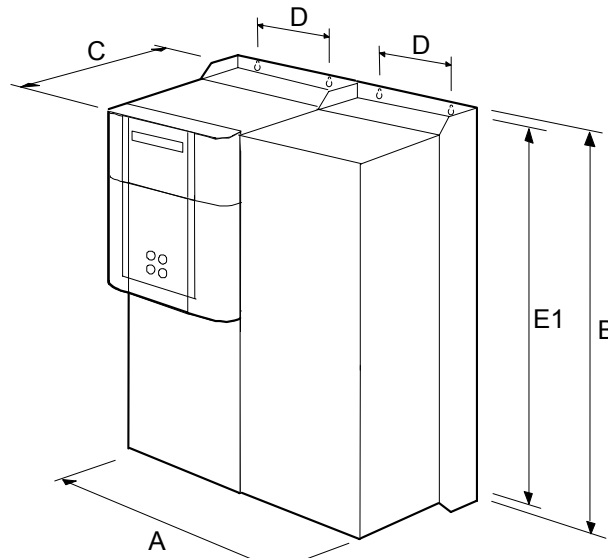

1580A
Frame 5
 (vent kit assemblies not shown)

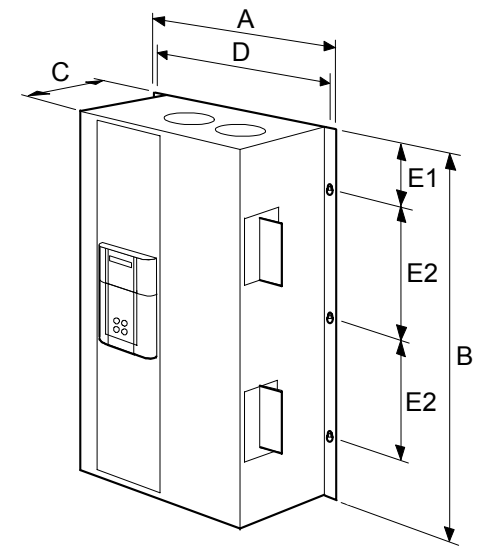

1200A - 2700A
Frame H

Boxed (KG)	Current Rating (A)	Weight Kg (lbs)	Overall Dimensions			Fixing Centres		
			A	B	C	D	E1	E2
L100 W40 H50 50	380	32 (71)	253 (10.0)	700 (27.6)	358 (14.2)	150 (5.9)	680 (26.8)	-
L100 W40 H50 50	500	32 (71)	253 (10.0)	700 (27.6)	358 (14.2)	150 (5.9)	680 (26.8)	-
L100 W40 H50 53	725	44 (97)	253 (10.0)	700 (27.6)	358 (14.2)	150 (5.9)	680 (26.8)	-
L100 W40 H50 53	830	44 (97)	253 (10.0)	700 (27.6)	358 (14.2)	150 (5.9)	680 (26.8)	-
	1580	90 (200)	506 (20.0)	700 (27.6)	358 (14.2)	150 (5.9)	680 (26.8)	-
	1200 - 2700	See *	850 (33.5)	1406 (55.3)	417 (16.4)	810 (31.9)	78 (3.1)	4 x 400 (15.7)
	1200 - 2700	See *	850 (33.5)	956 (37.6)	417 (16.4)	810 (31.9)	78 (3.1)	3 x 400 (15.7)

*590+ drive weighs 270Kg (595.4 lbs) without packaging and fan assembly
 591+ drive weighs 160kg (352.8 lbs) without packaging and fan assembly
 Fan weighs 18.5Kg (40.8 lbs)
 Dimensions are in millimetres (inches)
 Refer to "Installation Drawings", page 3-75.

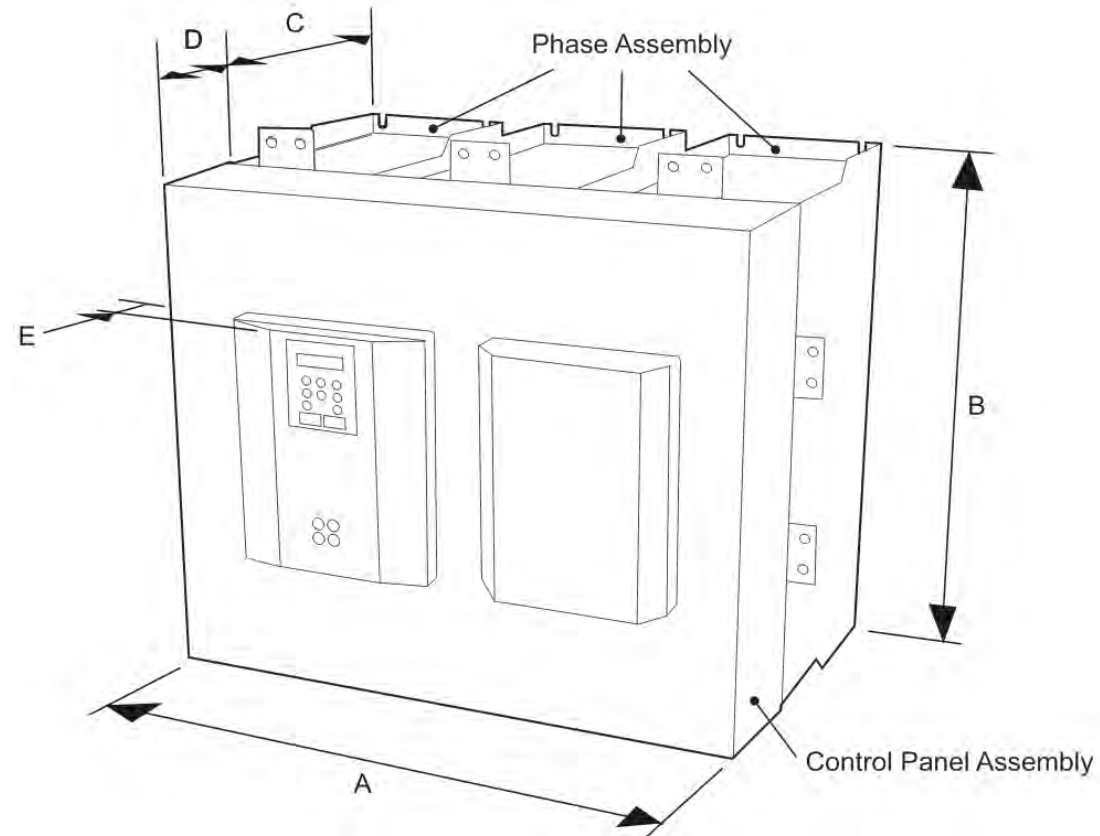

1250 - 1950A
Frame 6

A	B	C	D	E
686 (27.00)	715 (28.15)	378 (14.88)	62 (2.44)	57 (2.24)
<i>Dimensions are in millimetres (inches)</i>				
Weights: Control Panel Assembly Regen Phase Assembly (4Q) Non-Regen Phase Assembly (2Q)		11.25kg (25 lbs) 33kg (73 lbs) each 28kg (62 lbs) each		The DC590+ Frame 6 drive is assembled <i>in-situ</i> . Refer to "Frame 6: Assembly and Installation" page 3-63 for detailed build instructions.

Mounting the Drive

NOTE General installation details are given below for mounting the Drive, however, if you are installing the unit with an EMC filter refer to “External AC Supply EMC Filter Installation, page 3-60.

Mount the unit vertically on a solid, flat, vertical surface. It is mounted using bolts or screws into four fixing points (keyhole slots). The design allows the use of 100mm grid fixing.

It must be mounted inside a suitable cubicle. To comply with the European safety standards VDE 0160 (1994)/EN50178 (1998), the cubicle must require a tool for opening.

NOTE Holes for the mounting bolts or screws must be placed accurately.

Cover any units already mounted to the panel to protect them from stray metal filings while drilling mounting holes.

General Mounting Hints

Caution

Use proper lifting techniques when lifting and moving.

Drill the mounting holes into the backplate. The holes must be positioned accurately. Fit the nut inserts. Fit bolts and washers into the top inserts so that the drive can be hung using the keyhole slots.

Hang the drive on the bolts, between the panel and washers you have just fitted. Fit bolts and washers to the lower nut inserts. Finally, use the socket wrench to tighten all nuts securely.

Check the drive and its housing for packing material, mounting debris, or any other material that could damage and/or restrict the operation of the equipment.

Recommended Tools

Socket wrench	With a 6 Inch extension
Deep sockets	M6, M10, M13, M17, 7/16", 1/2"
Screwdrivers	Phillips No.2, flat blade - 0.5 x 3.0mm, 0.8 x 4.0mm
Wire cutters	Small

Ventilation and Cooling Requirements

NOTE When fitting a drive into a sealed enclosure additional cooling **MUST** be provided, otherwise the internal air will overheat causing the drive to trip on "overtemperature".

Refer to Appendix E: "Technical Specifications" - Cooling Fans.

The Drive gives off heat during normal operation and must therefore be mounted to allow the free flow of air through the air entries and exits. Maintain the minimum air clearances given on the drawings to ensure that heat generated by other adjacent equipment is not transmitted to the Drive. Be aware that other equipment may have its own clearance requirements. When mounting two or more DC590+'s together, these clearances are cumulative.

Ensure that the mounting surface is normally cool.

Installing the Fan (Frame H)

Refer to Appendix E: "Technical Specifications" - Cooling Fans.

The fan unit supplied should be installed on the cubicle, with or without ducting (refer to the Installation Drawing). The drive is force-cooled using the fan units supplied with the drive. As a general rule allow at least 150mm (6 inches) of clear space above and below the drive for free air flow. We suggest the cubicle has an air inlet at the base of the cubicle equivalent to 0.37m^2 (4ft^2), variable depending upon the filter type used, to allow the maximum throughput of air.

The fan assembly provided is permanently wired as shown below.

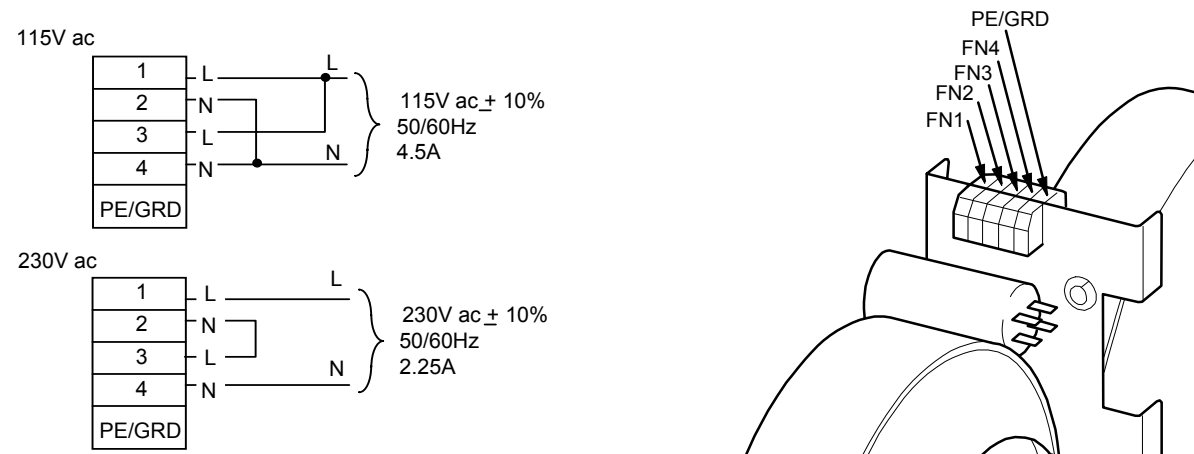

Figure 3- 2 Frame H Fan Wiring Diagram

Installing the External Vent Kit (Frames 4 & 5)

Parker SSD Part Drives Numbers:

Frame 4 : LA466717U001

Frame 5 : LA466717U002

Refer also to page 3-80 and page 3-85.

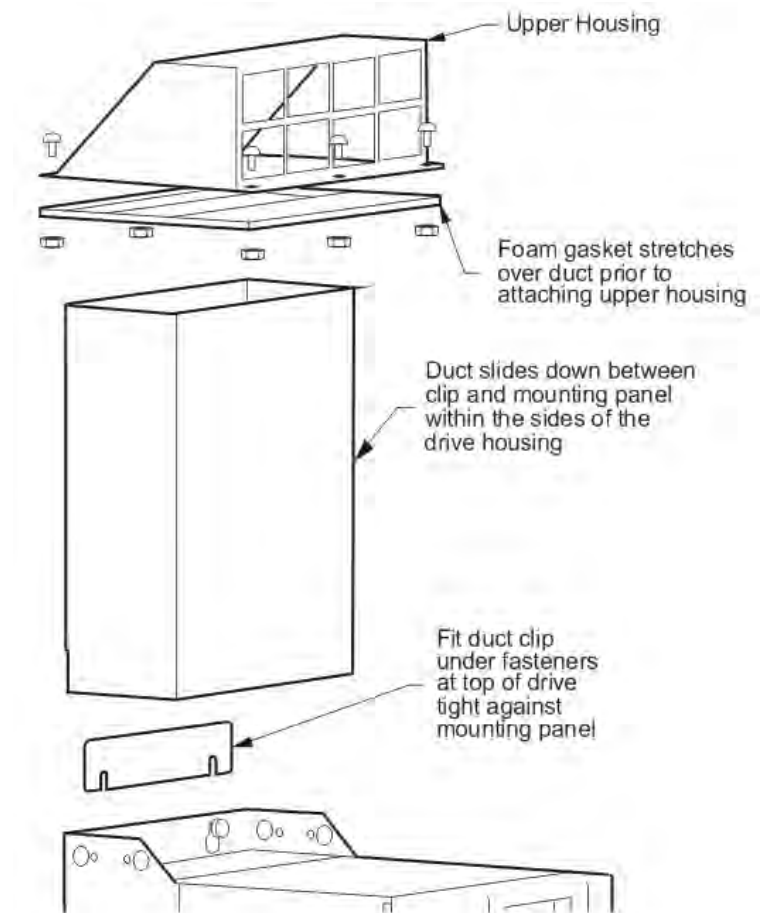

Figure 3-3 Frames 4 & 5 External Vent Kit

AC Line Choke

We recommend that you always use the specified ac line choke with the Drive to provide a known supply impedance for effective operation of the thyristor transient suppression circuits. At least 1% line impedance should be provided in the supply side of the drive.

Refer to Appendix E: “Technical Specifications” - AC Line Choke for selection details.

Filtering

NOTE Refer to Appendix B: "Certification" - EMC.

For compliance in Europe with EN61800-3 Table 11:

- The CE marking of drives whose armature current >100A is applicable without filtering.
- The CE marking of drives whose armature current <100A is **only** applicable with filtering. The drive requires one of the following:
 1. The specified filter given in Appendix B
(also refer to External AC Supply EMC Filter Installation, page 3-60)
 2. Compliant filtering offered by the System
 3. Capacitors fitted between phase and earth (see Figure 3- 4 below)

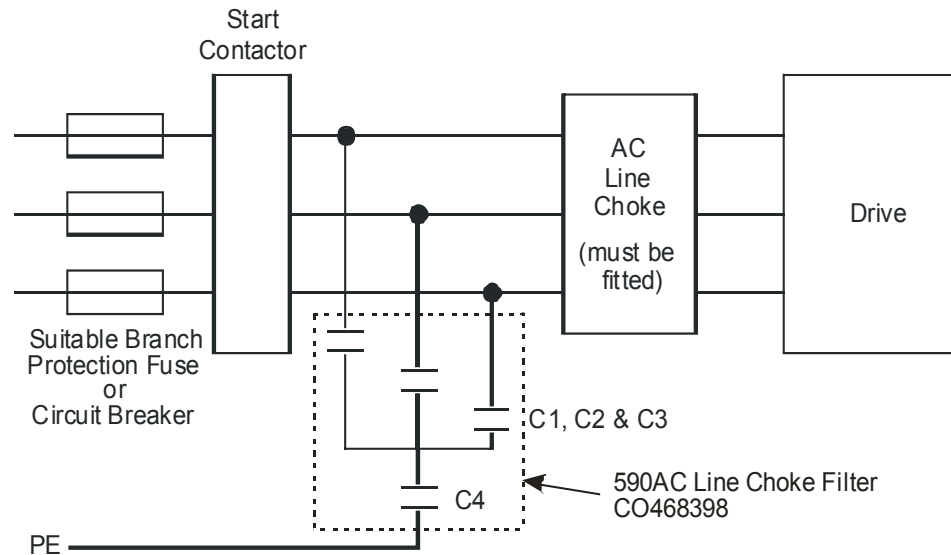

Capacitor Reference Number	Capacitor Value/Type
C1, C2, C3	3.0 μ F 400V, EMI suppressor type Class X1
C4	1.0 μ F 400V, EMI suppressor type Class X1

Figure 3- 4 AC Line Choke and Capacitors fitted to Frame 1 (15A & 35A) & Frame 2 (40A & 70A) Drives